

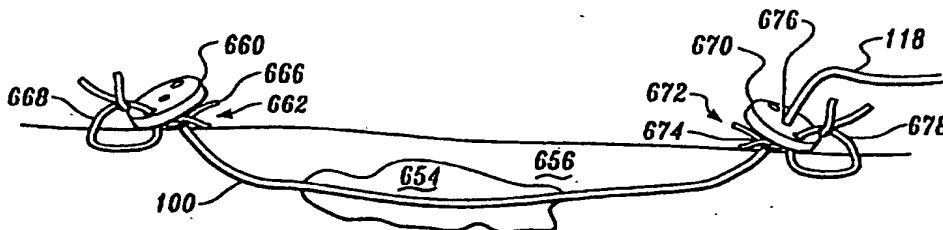

INTERNATIONAL APPLICATION PUBLISHED UNDER THE PATENT COOPERATION TREATY (PCT)

(51) International Patent Classification 6 : A61B 5/04, 17/36, 19/00, A61N 1/00	A1	(11) International Publication Number: WO 97/32520 (43) International Publication Date: 12 September 1997 (12.09.97)
<p>(21) International Application Number: PCT/US97/02459</p> <p>(22) International Filing Date: 14 February 1997 (14.02.97)</p> <p>(30) Priority Data: 08/613,390 7 March 1996 (07.03.96) US 08/633,171 16 April 1996 (16.04.96) US</p> <p>(71) Applicant: LIGHT SCIENCES LIMITED PARTNERSHIP [US/US]; 1065 - 12th Avenue N.W. #E5, Issaquah, WA 98027 (US).</p> <p>(72) Inventors: CHEN, James, C.; 2011 - 87th Place N.E., Bellevue, WA 98004 (US). WISCOMBE, Brent; 3014 East Holmes, Mesa, AZ 85204 (US).</p> <p>(74) Agent: ANDERSON, Ronald, M.; Law Offices of Ronald M. Anderson, Suite 1710, 500 - 108th Avenue N.E., Bellevue, WA 98004 (US).</p>	<p>(81) Designated States: AL, AM, AT, AU, AZ, BA, BB, BG, BR, BY, CA, CH, CN, CU, CZ, DE, DK, EE, ES, FI, GB, GE, HU, IL, IS, JP, KE, KG, KP, KR, KZ, LC, LK, LR, LS, LT, LU, LV, MD, MG, MK, MN, MW, MX, NO, NZ, PL, PT, RO, RU, SD, SE, SG, SI, SK, TJ, TM, TR, TT, UA, UG, UZ, VN, ARIPO patent (KE, LS, MW, SD, SZ, UG), Eurasian patent (AM, AZ, BY, KG, KZ, MD, RU, TJ, TM), European patent (AT, BE, CH, DE, DK, ES, FI, FR, GB, GR, IE, IT, LU, MC, NL, PT, SE), OAPI patent (BF, BJ, CF, CG, CI, CM, GA, GN, ML, MR, NE, SN, TD, TG).</p> <p>Published With international search report.</p>	

(54) Title: FLEXIBLE MICROCIRCUITS FOR INTERNAL LIGHT THERAPY



(57) Abstract

A plurality of embodiments for a flexible probe used to provide photodynamic therapy (PDT) and to effect other medical procedures at an internal treatment site inside a patient's body. Each of the embodiments of the flexible probe (100, 108, 130, 158, 182, 190, 220, 280, 370, 390, 440, 460, 520) includes a flexible substrate (102, 184, 196, 222, 250, 282, 412, 462, 482, 502, 522) on which are disposed conductive traces (414, 466, 468, 488, 490, 504, 506, 524, 526) electrically connected to leads through which electrical current and signals are conveyed. A plurality of light sources (104, 192, 256, 286, 418, 436, 470, 492, 508, 542) or other micro-electronic circuits are connected to the conductive traces and mounted on the flexible substrate. Each of the embodiments of the flexible probes is enclosed within a transparent, biocompatible polymer envelope (106, 110, 464, 522). Due to the characteristic elastic properties of the flexible substrate, the flexible probe can readily be bent, folded or rolled while being disposed at the internal treatment site. Thus, for example, a curved surgical needle (650) can be used to implant a flexible probe at the treatment site by drawing the flexible probe through tissue along a curved path to a desired position; one or more disk-shaped buttons (660, 670) that are attached to the ends of the flexible probe can be used to secure the flexible probe so that it does not move from the desired position.

FOR THE PURPOSES OF INFORMATION ONLY

Codes used to identify States party to the PCT on the front pages of pamphlets publishing international applications under the PCT.

AM	Armenia	GB	United Kingdom	MW	Malawi
AT	Austria	GE	Georgia	MX	Mexico
AU	Australia	GN	Guinea	NE	Niger
BB	Barbados	GR	Greece	NL	Netherlands
BE	Belgium	HU	Hungary	NO	Norway
BF	Burkina Faso	IE	Ireland	NZ	New Zealand
BG	Bulgaria	IT	Italy	PL	Poland
BJ	Benin	JP	Japan	PT	Portugal
BR	Brazil	KE	Kenya	RO	Romania
BY	Belarus	KG	Kyrgyzstan	RU	Russian Federation
CA	Canada	KP	Democratic People's Republic of Korea	SD	Sudan
CF	Central African Republic	KR	Republic of Korea	SE	Sweden
CG	Congo	KZ	Kazakhstan	SG	Singapore
CH	Switzerland	LI	Liechtenstein	SI	Slovenia
CI	Côte d'Ivoire	LK	Sri Lanka	SK	Slovakia
CM	Cameroon	LR	Liberia	SN	Senegal
CN	China	LT	Lithuania	SZ	Swaziland
CS	Czechoslovakia	LU	Luxembourg	TD	Chad
CZ	Czech Republic	LV	Latvia	TG	Togo
DE	Germany	MC	Monaco	TJ	Tajikistan
DK	Denmark	MD	Republic of Moldova	TT	Trinidad and Tobago
EE	Estonia	MG	Madagascar	UA	Ukraine
ES	Spain	ML	Mali	UG	Uganda
FI	Finland	MN	Mongolia	US	United States of America
FR	France	MR	Mauritania	UZ	Uzbekistan
GA	Gabon			VN	Viet Nam

FLEXIBLE MICROCIRCUITS FOR INTERNAL LIGHT THERAPY

Related Application

This application is a continuation-in-part application, based on prior copending application Serial No. 08/613,390, filed on March 7, 1996, the benefit of the filing date of which is hereby claimed under 35 U.S.C. § 120.

Field of the Invention

This invention generally relates to a method for using a probe on which is disposed an electronic device used to effect a medical procedure in a patient's body, and more specifically, to a probe adapted for insertion into a patient's body through an incision or natural body opening, to implement the medical procedure at a site within the patient's body.

Background of the Invention

Abnormal cells in the body are known to selectively absorb certain dyes perfused into a treatment site to a much greater extent than surrounding tissue. For example, tumors of the pancreas and colon may absorb two to three times the volume of certain dyes, compared to normal cells. Once pre-sensitized by dye tagging, the cancerous or abnormal cells can be destroyed by irradiation with light of an appropriate wavelength or waveband corresponding to an absorbing wavelength or waveband of the dye, with minimal damage to normal tissue. This procedure, which is known as photodynamic therapy (PDT), has been clinically used to treat metastatic breast cancer, bladder cancer, lung carcinomas, esophageal cancer, basal cell carcinoma, malignant melanoma, ocular tumors, head and neck cancers, and other types of malignant tumors. Because PDT may selectively destroy abnormal cells that have absorbed more of the dye than normal cells, it can successfully be used to kill malignant tissue with less effect on surrounding benign tissue than alternative treatment procedures.

Typically, invasive applications of PDT have been used during surgical procedures employed to gain access to a treatment site inside the body of the patient to administer light produced by relatively high intensity light sources, such

as high power lasers or solid state laser diode (LD) arrays. Optical fibers in a hand-held probe are often used to deliver the intense light to the surgically exposed treatment site from a remote source to reduce damage to surrounding tissue from the heat developed by the light source.

5 It has been shown possible, in certain cases, to obtain improved therapeutic results in PDT at a low light level. As reported by J. A. Parrish in "Photobiologic Consideration in Photoradiation Therapy," pp. 91-108, Porphyrin Photosensitization, Plenum Press, (1983), preliminary laboratory studies with hematoporphyrin and visible light suggest that low intensity light may be more
10 effective in PDT. In these experiments, subcutaneous tumors in the flanks of newborn rats were treated with the same external dose of 620 nm radiation, at intensities of 7.5, 28, and 75 mW/cm². At the same total light dosage, Parrish found that greater tumor necrosis occurred at the lowest light intensity used.

Light emitting probes designed to be transcutaneously introduced into the
15 body of a patient at a desired treatment site, to administer PDT using low light level sources, for extended periods of time, are taught in commonly assigned U.S. Patent No. 5,445,608, the drawings and disclosure of which are specifically incorporated herein by reference. Several different embodiments of such probes are illustrated and discussed in this patent. Each of the probes disclosed in this
20 reference includes a plurality of light sources that are mounted on a relatively stiff or inflexible substrate and enclosed within a transparent envelope through which light emitted by the light sources is transmitted to the tumor or other cells to be destroyed by the PDT. The light sources used on the probes taught by this reference are preferably light emitting diodes (LEDs). By transcutaneously
25 inserting one of these probes into an internal treatment site and applying PDT over an extended time frame, abnormal cells at the treatment site can be destroyed without adverse impact on normal cells.

None of the implantable light emitting probes disclosed in the above-referenced patent include light sources mounted on flexible substrates. There are
30 many applications for PDT in which it would be advantageous to use a flexible substrate for mounting the LEDs or other light sources on a probe used to administer the PDT, e.g., so that the probe can be threaded into a treatment site through a curved passage within the patient's body without risk of perforation of the passage wall. In contrast to the relatively inflexible substrate used in the probes disclosed in the above-referenced patent, a flexible PDT probe could be
35 folded or rolled into a smaller cross-sectional size for insertion into a treatment

5 site through an incision or body passage and then allowed to deploy, unfolding or unrolling into a larger size for administration of low intensity light to the treatment site. Alternatively, a flexible probe could be molded around an irregularly shaped tumor or organ or rolled around a lumen, such as a blood vessel, or unfurled inside a passage or cavity of an organ or lumen to irradiate its interior with light emitted by the probe. In addition, a flexible probe would be able to change shape to adapt to changes in the treatment site, as malignant tissue is destroyed by the PDT, and should be able to move with an organ (such as the lung or heart) or blood vessel, due to a physiological displacement or change in the shape of the organ or vessel, without interfering with the function of the organ or vessel. The prior art does not disclose a flexible probe capable of providing these capabilities.

15 It is also apparent that a flexible probe could more readily be introduced to a treatment site for implementing medical procedures other than PDT. For example, a flexible probe that includes an ultrasonic transmitter and/or ultrasonic receiver could more readily be inserted into an organ or lumen to carry out an ultrasound scan of surrounding tissue relative to the site inside the organ or lumen. Furthermore, a flexible probe that is used to administer PDT can be provided with electronic components capable of carrying out additional functions. For example, a sensor to determine the efficacy of the PDT treatment might be included on a flexible probe, in addition to the plurality of LEDs or other light sources that are used to provide light to a treatment site.

20 A flexible probe on which an electronic circuit for administering a medical treatment or a sensing device is mounted can more readily be threaded into an internal site than a rigid or inflexible probe, and the insertion procedure can be implemented with less trauma to a patient. In addition, a flexible probe is less likely to cause an unwanted and potentially harmful perforation, or to move from a treatment site within a patient's body. Thus, there are significant advantages to be realized in using a flexible probe rather than a relatively rigid probe for administering medical treatment or carrying out diagnostic procedures. By inserting a flexible probe into the patient's body through a small incision and threading it to a site where it will be used in a medical procedure, the patient would likely be exposed to less risk of infection and loss of blood than is occasioned by the more extensive surgery used in conventional applications of the treatment. Further, a flexible probe may be left in place at a treatment site longer, due to the minimal impact it has on the patient's normal physiological functions

and due to its ability to adjust to changing conditions at the treatment site. For these and other reasons that will be evident from the following disclosure, a flexible probe offers substantial advantages over prior art approaches to administering PDT and other types of medical treatment to an internal treatment site within a patient's body.

Because it can be readily deformed around a curved path, a flexible probe can more easily be conveyed to an internal treatment site than a rigid probe. Endoscopic techniques can be applied for moving a flexible probe through a body passage and positioning it at or within a treatment site. It would be desirable to use a curved pointed object to draw a flexible probe along a curved path, defining a desired position for the flexible probe at a treatment site disposed within abnormal tissue. Once positioned at the treatment site, it will likely be necessary to affix the probe, preventing its displacement away from the site due to natural physiological movement. Thus, some means would probably be required to ensure that the flexible probe is secured in place.

Summary of the Invention

The present invention is directed to a method for implanting and fixing a flexible probe in a desired position at a treatment site within a patient's body. The method uses a flexible probe that includes an elongate strip having sufficient flexibility to sustain deformation and bending without damage. The strip is attached to a surgical needle, and the surgical needle is forced through tissue to the treatment site within the patient's body. The strip comprising the flexible probe is drawn into the tissue by the surgical needle, along a path of the surgical needle. Once the strip is implanted with the surgical needle in the desired position at the treatment site, the surgical needle is disconnected from the strip. The surgical needle is then withdrawn from the tissue, leaving the strip disposed in the desired position within the patient's body to administer the medical treatment to the treatment site.

The method further includes the step of securing one end of the strip to a first object. The first object has a substantially greater cross-sectional size than the strip and serves to anchor the strip in the desired position at the treatment site, preventing movement of the strip relative to the treatment site. Optionally, the first object may be secured to a tissue surface in the patient's body.

In addition, the method may include the step of securing another end of the strip to a second object. Like the first object, the second object has a substantially greater cross-sectional size than the strip and further serves to anchor the strip in

the desired position at the treatment site, preventing movement of the strip relative to the treatment site. The second object preferably includes a sleeve that slips over the strip. A lead that is coupled to the strip extends through the sleeve. The method further preferably includes the step of securing the second object to the strip after the strip is disposed at the desired position. The step of securing the first and/or the second object to the strip may be accomplished either by crimping the sleeve of the object about the strip, by affixing the object with a threaded fastener (e.g., a set screw disposed in the sleeve), by inserting a pin through the sleeve and the strip, or by adhesively connecting the object to the strip, or by affixing the object to the strip in some other manner, such as with a suture.

In addition, the step of forcing the surgical needle may be accomplished by grasping the surgical needle with a needle holder, and/or pulling the surgical needle into the desired position with forceps.

Another aspect of the present invention is directed to apparatus for administering a medical procedure to a treatment site disposed within a patient's body. Elements of the apparatus are generally consistent with those noted in the above description of the method, and the components of the apparatus perform substantially the functions implemented in the steps of the method described above.

Brief Description of the Drawing Figures

The foregoing aspects and many of the attendant advantages of this invention will become more readily appreciated as the same becomes better understood by reference to the following detailed description, when taken in conjunction with the accompanying drawings, wherein:

FIGURE 1 is a greatly enlarged side view of a distal portion of a first embodiment of a flexible probe in accord with the present invention;

FIGURE 2 shows cross-sectional views of four different profiles of the flexible probe;

FIGURE 3 is a greatly enlarged side view of a distal portion of a second embodiment of the flexible probe;

FIGURE 4 is side elevational view of a straight guide tube through which the flexible probe is delivered to an internal treatment site, showing the flexible probe being guided through a lumen of the guide tube;

FIGURE 5 is a side elevational view of a curved guide tube through which the flexible probe is delivered to an internal treatment site, showing the flexible probe being guided through a lumen of the guide tube;

6

FIGURE 6A is a side view of the straight guide tube of FIGURE 4, showing the guide tube used to deliver the second embodiment of the flexible probe to a treatment site inside a tumor or other type of tissue mass;

5 FIGURE 6B is a side view of the straight guide tube, showing it being drawn back from the treatment site over an electrical lead that is coupled to the second embodiment of the flexible probe;

FIGURE 7 is a side view showing the flexible probe sutured to a tissue layer to secure the flexible probe in a treatment site;

FIGURE 8 is an isometric view of a prior art peel-away sheath;

10 FIGURE 9 is a plan view of the prior art peel-away sheath of FIGURE 8;

FIGURE 10 is a side view of the prior art peel-away sheath of FIGURE 8 and a prior art lancet that is used to position the peel-away sheath in a tissue mass;

FIGURE 11 is a side view showing the prior art lancet being withdrawn from the peel-away sheath of FIGURE 8;

15 FIGURE 12 is a side view showing the flexible probe being positioned in the tissue mass through the peel-away sheath of FIGURE 8;

FIGURE 13 is a side view illustrating how the peel-away sheath is removed from the second embodiment of the flexible probe by splitting the guide tube longitudinally while withdrawing it from the tissue mass;

20 FIGURE 14 is an isometric cut-away view of a third embodiment of the present invention and a catheter for inserting a plurality of flexible probes through a body passage to a treatment site within a patient's body;

FIGURE 15 is a sectional view of a penis, showing the third embodiment in a catheter that is inserted into a bladder through a urethra passage;

25 FIGURE 16A is a sectional view of the bladder, showing the catheter being withdrawn and the plurality of flexible probes splaying apart inside the bladder;

FIGURE 16B is a side view of a portion of a fourth embodiment of a flexible probe formed as a loop, shown in a flattened or compressed state;

30 FIGURE 16C is a side view of the fourth embodiment of the flexible probe in an open, uncompressed state;

FIGURE 16D is a sectional view of the bladder in which a plurality of probes in accord with the fourth embodiment are shown in a splayed array as the catheter used to introduce the probes into the bladder is withdrawn;

35 FIGURE 17 is an isometric view of a fourth embodiment of the flexible probe configured as a flexible sheet;

7

FIGURE 18 is an isometric view of the fourth embodiment of the flexible probe folded to reduce its transverse size and tied with a suture to restrain it in the folded configuration;

5 FIGURE 19 is an isometric view of the fourth embodiment of the flexible probe folded to reduce its transverse size and clipped with a U-shaped clip to restrain it in the folded configuration;

FIGURE 20 is an isometric view of the fourth embodiment of the flexible probe folded to reduce its transverse size and clipped with a rectangular-shaped band to restrain it in the folded configuration;

10 FIGURE 21 is a sectional view of the fourth embodiment of the flexible probe, showing the flexible probe being pulled by forceps from opposite ends to unfold it at a treatment site in a body lumen;

FIGURE 22 is a side view of the fourth embodiment of the flexible probe, showing the sheet rolled into a cylindrical configuration;

15 FIGURE 23 is an end view of the rolled flexible probe of FIGURE 22;

FIGURE 24 is an end view of the rolled flexible probe of FIGURE 22, restrained in a cylindrical sleeve;

FIGURE 25 is an elevational view of the rolled flexible probe of FIGURE 24;

20 FIGURE 26 is a sectional view of a portion of a patient's torso, showing the rolled fourth embodiment being positioned at a treatment site through an access tube that extends through the cutaneous layer;

FIGURE 27 is a sectional view of the portion of the torso, showing the restraining sleeve being removed from the rolled flexible probe;

25 FIGURE 28 is a sectional view of a treatment site inside a patient's body, showing the flexible probe being unrolled at the treatment site;

FIGURE 29 is a sectional view of an internal passage in a patient's body in which the rolled flexible probe has been inserted;

30 FIGURE 30 is the sectional view of the internal passage showing the flexible probe held in position by sutures that connect loops on the flexible substrate to interior surfaces of the passage;

FIGURE 30A is an isometric view of the rolled flexible probe, restrained by a suture that holds opposite ends of the rolled configuration in place;

35 FIGURE 31 is an isometric view of the fourth embodiment of the flexible probe rolled around a body lumen having a first cross-sectional size;

FIGURE 32 is an isometric view of the fourth embodiment of the flexible probe rolled around a body lumen having a second cross-sectional size, showing how the rolled diameter of the flexible probe increases to accommodate physiological changes at a treatment site;

5 FIGURE 33 is a sectional view of a patient's organ showing a fifth embodiment of the flexible probe that includes a balloon cuff, with lumens and leads extending through an opening in the patient's skin;

FIGURE 34 is an isometric view of the fifth embodiment of the flexible probe;

10 FIGURE 35 is a side view of the fifth embodiment of the flexible probe;

FIGURE 36 is a sectional view showing a flexible probe threaded through a nasal passage and into the entrance of a patient's stomach;

FIGURE 37 is sectional view of a portion of the esophagus in which the flexible probe has been threaded;

15 FIGURE 38 is a sectional view showing a flexible probe having electrical lines attached to one end and a suspension lead attached to the other end and extending through the esophagus and out through the nasal passage of a patient;

FIGURE 39 is a sectional view of a portion of the esophagus in which the flexible probe of FIGURE 38 is disposed;

20 FIGURE 40 is a side view of a sixth embodiment of the flexible probe in which a soft tip is temporarily attached to a distal end of the probe so that peristalsis advances the probe into the bowel;

FIGURE 41 is a sectional view of the bowel, showing the flexible probe sutured in place and a proximal end of an attached lead passing through a gastrostomy site in the stomach and out through the abdominal wall;

25 FIGURE 42 is a sectional view of a bowel, showing the flexible probe sutured at a treatment site inside the bowel and leads extending outside the abdominal cavity through a stoma site;

FIGURE 43 is a side view of a branching artery, showing a seventh embodiment of the flexible probe coiled about the artery;

FIGURE 44 is an isometric view of a heart showing the fourth embodiment of the flexible probe overlying a cardiac vessel;

FIGURE 45 is a sectional view of a cardiac vessel showing arteriosclerosis plaque built up on the interior surface;

35 FIGURE 46 is a plan view of a flexible substrate upon which a plurality of LEDs can be mounted to produce a plurality of flexible probe circuits;

9

FIGURE 47 is a plan view of a single flexible substrate probe substrate and conductive strips for mounting a plurality of LEDs;

FIGURE 48 is an enlarged side view of a distal end of a flexible probe in which a plurality of LEDs are mounted on opposite sides of flexible substrates;

5 FIGURE 49 is a cross-sectional view of the flexible probe shown in FIGURE 48;

FIGURE 50 is a block diagram of a system for administering PDT using the flexible probe;

FIGURE 51 is a plan view of the PDT flexible probe;

10 FIGURE 52 is a block diagram showing the components of a PDT system that uses a flexible probe;

FIGURE 53 is a greatly enlarged cut-away view of an embodiment of a flexible probe in which light sources are mounted between two facing flexible substrates;

15 FIGURE 54 is a cross-sectional view of the embodiment shown in FIGURE 53;

FIGURE 55 is a plan view of another embodiment of a flexible probe formed as a sheet, for administering PDT;

20 FIGURE 56 is a cross-sectional view of the embodiment of FIGURE 55, taken along section lines 56-56;

FIGURE 57 is an isometric view of a portion of an embodiment in which LEDs having two characteristic wavebands are mounted between conductive traces on a flexible substrate, with the polarities of the LEDs having one characteristic waveband reversed relative to those having the other characteristic waveband;

25 FIGURE 58 is a cross-sectional elevational view of the embodiment of the flexible probe shown in FIGURE 57;

FIGURE 59 is a plan view of a planar array of LEDs mounted on a flexible substrate that is encapsulated in a transparent material;

30 FIGURE 60 is a sectional view of a pair of conductive traces on which an LED is mounted on a reflector;

FIGURE 61 is an isometric view of power transmitter and receiver coils disposed on opposite sides of a cutaneous layer;

35 FIGURE 62 is an alternative embodiment of power transmitter and receiver coils disposed on opposite sides of a cutaneous layer;

10

FIGURE 63 illustrates an infrared source and receiver disposed on opposite side of a cutaneous layer, for transmitting power for the flexible probe;

FIGURE 64 is an exploded isometric view showing a distal end of the flexible probe and an object that is affixed to the flexible probe;

5 FIGURE 65 is a sectional view showing a path described by a curved surgical needle that is used to implant a flexible probe at a treatment site;

FIGURE 66 is a sectional view showing the flexible probe of FIGURE 65 secured at the treatment site by an object attached to the flexible probe; and

10 FIGURE 67 is a sectional view showing the flexible probe of FIGURE 66 with a second object attached to the other end of the flexible probe to secure it at the treatment site.

Description of the Preferred Embodiment

Elongate Flexible Probes

15 A first embodiment of a flexible probe 100 in accordance with the present invention is illustrated in FIGURE 1. Flexible probe 100 is elongate in shape and comprises a flexible substrate 102 comprising a polymer material that readily bends without breakage. In an initial prototype of the flexible probe, the polymer material used is approximately 0.002" thick and comprises Kapton™ polyimide film, which is sold by E. I. DuPont De Nemours & Co. Other types of polymers
20 and thinner material can be used for the flexible substrate in each of the embodiments of the present invention that are described below. The flexible substrate comprising flexible probe 100 (and the other embodiments described below) is sufficiently flexible and strong to enable it to be folded back on itself (through an angle of about 180°) along a line, rolled, twisted, and otherwise
25 distorted, without any damage to the substrate or to conductive traces (discussed below in regard to FIGURE 46) that are applied to the flexible substrate.

Although not shown in FIGURE 1, a plurality of conductive traces are applied to flexible substrate 102 to convey an electrical current to energize a plurality of light emitting sources 104 that are mounted on and supported by the
30 flexible substrate. In connection with this invention, it is also contemplated that other types of electronic microcircuits may be mounted on the flexible substrate instead of, or in addition to, light emitting sources 104. Such electronic microcircuits may include ultrasonic transmitters and emitters, sensors such as photodetectors, and other electronic circuitry for use in effecting either a medical
35 treatment or a diagnostic function using the flexible probe within a patient's body. It should be noted that the present invention is not limited for use with human

patients, but may also be used, for example, by veterinarians to treat and/or diagnose medical problems in pets, livestock and other animals. For use in administering light during PDT, flexible substrate 102 and light emitting sources 104 are enclosed in a clear (light transparent) biocompatible polymer envelope 106. In this and other of the embodiments intended for use in providing PDT, the light emitting sources preferably comprise LEDs; however, it is also contemplated that other types of light emitting electronic circuits, such as laser diodes or a thin film electroluminescent panel can alternatively be fabricated on the flexible substrate for use in administering the PDT. For example, thin film electroluminescent display panels using ZnS:Mn phosphors are well known in the prior art and the flexible substrate is equally applicable as a support for a plurality of conductive traces, between which are sandwiched the light-emitting phosphor layers.

FIGURE 2 illustrates various other cross-sectional shapes for the envelope provided for the flexible probe. These shapes include an envelope 106' that has a rectangular cross section and encloses a flexible substrate 102', which is sufficiently broad to enable a plurality of light emitting sources 104 to be mounted across its width. Also illustrated are an envelope 106", which has a generally half-round cross-sectional shape, and an envelope 106''' an equilateral triangle cross-sectional shape. The various cross-sectional shapes illustrated for the envelope in FIGURE 2 are merely exemplary of various cross-sectional shapes contemplated for use with flexible probes made in accordance with the present invention.

No attempt is made in this disclosure to teach optimum exposure times and light intensities for conducting PDT using the present invention. Planned clinical trials will help to determine such variables for various types of abnormal tissue and in regard to patient specific variables. The basis premises of PDT are well known to those of ordinary skill in this art and need not be recited to fully disclose the present invention. For example, a variety of photoreactive agents are known, as evident from references such as "Photosensitizing Activity of Water and Lipid-Soluble Phthalocyanines on *Escherichia coli*," Bertoloni et al., "Photodynamic Effects of Dyes on Bacteria," Webb et al., "Phototoxicity of Quinilone Methanols and Other Drugs," Ison et al., "Research Progress in Organic-Biological and Medicinal Chemistry," Ballio et al., "Photodynamic Therapy with Endogenous Protoporphyrin," Kennedy et al., and "Immunophototherapy for the Treatment of Cancer of the Larynx," Schlager et al. It is contemplated that conventional

photoreactive agents of the types discussed in the preceding references can be very effective in implementing PDT using the present invention. Eventually, it is likely that even more effective photoreactive agents will be identified for use in extended term PDT, which the present invention is well suited to provide.

5 In FIGURE 3, a second embodiment of a flexible probe 108 is illustrated. Flexible probe 108 differs from the first embodiment by including a flexible envelope 110 on which is formed a loop 112. Loop 112 includes an orifice 114, which as shown below, provides an attachment point for temporarily mounting flexible probe 108 in a fixed position at a treatment site inside a patient's body.
10 Flexible probe 108 also includes a barb 116 disposed at its distal end. Barb 116 is formed of the polymer material comprising envelope 110 and has a characteristic elasticity that causes the barb to flex to an open position in which it extends outwardly from the longitudinal axis of the flexible probe, as shown in FIGURE 3. However, because it is flexible, barb 116 can readily be closed to
15 minimize the cross-sectional area of flexible probe 108 at its distal end.

As explained below, flexible probes made in accordance with the present invention can be placed at a treatment site within a patient's body in ways that benefit from the flexibility of the flexible probe and its ability to bend or fold. In
20 FIGURE 4, a guide tube 120 is illustrated having a pointed end 122 for piercing a cutaneous layer (or other tissue layer) of a patient's body (not shown) or for piercing the outer surface of an internal organ in which is disposed a treatment site to which the flexible probe is to be advanced and left in place. In FIGURE 5, a
25 guide tube 120' is illustrated that has a predefined radius of curvature and a distal end terminating in a sharp point 122' for piercing the cutaneous layer or outer surface of an organ to facilitate placement of flexible probe 108. Due to the characteristic flexibility of flexible probe 108, it is easily advanced around the
30 radius of curvature of guide tube 120' for insertion and disposition at the treatment site within the patient's body. Electrical power and/or signals to and from the circuitry comprising the flexible probe are conveyed through leads 118, which extend either outside the patient's body or to a site remote from the treatment site where power and/or signals pass through the cutaneous layer of the patient's body. Details of such an arrangement are discussed below.

FIGURES 6A and 6B illustrate the steps involved in disposing flexible probe 108 at a treatment site within a tumor 124. Sharpened end 122 of guide
35 tube 120 is inserted into tumor 124 to an appropriate depth, e.g., just past the center of the tumor. Flexible probe 108 is either contained within guide tube 120 during its

13

insertion, or is subsequently inserted into the tumor through the inner passage of guide tube 120 after the guide tube has been positioned within tumor 124. Thereafter, guide tube 120 is withdrawn over the leads extending to flexible probe 108, as the flexible probe is held in place. Barb 116 flexes outwardly as the distal end of the flexible probe extends from the distal end of the guide tube. The barbs engage tissue inside tumor 124, preventing flexible probe 108 being pulled from inside tumor 124 as the guide tube is withdrawn. Optionally, a suture 126 may be used to secure loop 112 on flexible probe 108 to tumor 124 (or to another adjacent soft tissue structure). Guide tube 120 is withdrawn from the patient's body, and leads 118 are coupled to a power source and/or other instrumentation to activate the electronic circuits on the flexible probe.

An alternative embodiment of a flexible probe 130 is shown in FIGURE 7, following its insertion into tumor 124. Flexible probe 130 includes two loops 112 that extend outwardly from opposite sides of the flexible envelope. As shown in FIGURE 7, loops 112 are secured by sutures 131 to adjacent tissue 128 to retain flexible probe 130 fixed within tumor 124.

Another technique for inserting a flexible probe into tumor 124 (or into another type of tissue mass) employs a peel-away sheath 132, which is well known to those of ordinary skill in the art. Peel-away sheath 132 is shown in FIGURES 8-13, which illustrate its configuration and its use in placing flexible probe 108 at a treatment site within tumor 124. As shown in FIGURE 9, peel-away sheath 132 is shaped as an annular cylinder having frangible seams 134 disposed on opposite sides of the cylindrical sheath, extending longitudinally along its length. A lancet 138 having a sharpened point 122 is inserted inside a bore 136 of peel-away sheath 132, so that the sharpened point extends beyond the distal end of the sheath, and the assembly is inserted within tumor 124, as shown in FIGURE 10. Sharpened end 122 enables the assembly to readily pierce through a cutaneous layer or other tissue surface and enables the assembly to be readily advanced into tumor 124 (or into other types of tissue mass).

In FIGURE 11, lancet 138 is withdrawn from peel-away sheath 132, which remains temporarily fixed within a passage 140 in the tumor, produced by insertion of the assembly. Then, as shown in FIGURE 12, flexible probe 108 is inserted through the bore of peel-away sheath 132 and into passage 140 so that the flexible probe extends beyond the distal end of the peel-away sheath and inside tumor 124. The flexibility of the flexible probe facilitates threading it to the point in the patient's body where it can be inserted in the bore of the sheath. To reach

this point, it may be necessary to pass the flexible probe through a body lumen or along a curved path within the body. Finally, as shown in FIGURE 13, sides 132a and 132b of the peel-away sheath are split apart from each other along frangible seams 134 using forceps (endoscopic or conventional) 142. The forceps
5 simultaneously split the frangible seam and withdraw sides 132a and 132b from inside tumor 124. Flexible probe 108 is held in place within tumor 124 by barb 116, which engages tissue in the interior of the tumor.

Since a flexible probe made in accordance with the present invention can readily bend, it is easily threaded into a treatment site within a patient's body,
10 through an internal body or organ lumen. An example in which the present invention is used to apply PDT inside a male patient's bladder is illustrated in FIGURES 14-16 (A-D). In FIGURE 14, a urinary catheter 150 is illustrated that includes a central lumen 152. Within central lumen 152 is disposed a guide lumen 154, which exits urinary catheter 150 adjacent a proximal end of the
15 urinary catheter. Guide lumen 154 guides a bundle 156 of flexible probes 158 that are inserted into the guide lumen from its proximal end and extend just past the distal end of urinary catheter 150. Also disposed within lumen 152 is a balloon inflation lumen 160, having a distal end in fluid communication with a
20 balloon 170 that is disposed at the distal end of urinary catheter 150. Inflation lumen 160 is also in fluid communication with an external line 162, to which it is attached adjacent the proximal end of the urinary catheter. External line 162 terminates in a connector 164 that is suitable for connecting to a source of compressed air (or other type of fluid under pressure) used to inflate balloon 170. Balloon 170 extends annularly around the outer perimeter of the distal end of
25 urinary catheter 150, but is not inflated until after the distal end of the urinary catheter and balloon 170 have been inserted into the patient's bladder. Extending from the distal ends of each of the flexible probes 158 comprising bundle 156 are electrical lines 166, which are combined in leads 168. Leads 168 are connected to a source of electrical current and to instrumentation appropriate to process signals
30 conveyed from the flexible probes.

A portion of lumen 152 remains open along the entire length of urinary catheter 150, enabling urine to pass freely through lumen 152 to an external receptacle (not shown). As illustrated in FIGURE 15, urinary catheter 150 is threaded through a urethra 172, past a pubic bone 180, seminal glands 178, and
35 prostate gland 176 into a patient's bladder 174. Balloon 170 is then inflated with pressurized air or other pressurized fluid and the urinary catheter is drawn back

15

through urethra 172 so that balloon 170 seats within the opening into bladder 174, forming a sealing cuff. As urinary catheter 150 is drawn backwards along bundle 156, flexible probes 158 splay outwardly apart from each other, within the interior of bladder 174. Although not shown in FIGURE 16A, light sources
5 within each of flexible probes 158 are energized to provide PDT therapy to the interior surface of bladder 174 for treatment of tumors and other medical disorders that are appropriately treated using PDT.

FIGURES 16B-16D illustrate a flexible probe 182 in which the distal end of the flexible probe is turned back toward itself in a loop and adhesively attached
10 at a point 186, as shown in FIGURE 16C. The loop is sufficiently flexible to be collapsed, but its inherent elasticity causes it to spring into an open loop when not restrained. Inside flexible probe 182 is provided a flexible substrate 184 on which a plurality of light sources (not visible in the drawing figures) are mounted. As
15 illustrated in FIGURE 16B, use of flexible probes 182 in urinary catheter 150 to provide PDT inside a hollow organ, such as bladder 174, increases the total area of the flexible probe from which light is emitted and decreases any risk of perforating the organ wall with the tip of the flexible probe. When urinary catheter 150 is withdrawn from the bundle of flexible probes 182, the probes not
20 only splay outwardly from each other, but also each form an open loop to increase the total area from which light is emitted from the flexible probes.

Flexible Sheet Probes

In FIGURES 17-21, use of a flexible sheet probe 190 is illustrated in accordance with the present invention. Flexible sheet probe 190 includes a
25 generally quadrilateral shaped flexible substrate 196. This embodiment comprises a flexible substrate sheet that is substantially wider and longer than it is thick. It is contemplated that the flexible sheet probe can be made in any of a variety of different shapes, such as "T-shaped," "L-shaped," round, oval, etc., as is appropriate for a particular application. A plurality of light sources (or other micro-electronic circuits) 192 are mounted on opposite surfaces of flexible
30 substrate 196. Electrical power and/or signals are conveyed to each of light sources 192 (or other microcircuits) over leads 194, which are coupled to electrical traces disposed internally (not shown) between opposite outwardly facing surfaces of substrate 196.

FIGURE 18 illustrates how flexible sheet probe 190 is folded transversely
35 into three layers to reduce the cross-sectional width of the resulting package, thereby permitting the flexible sheet probe to be more readily inserted into a

16

treatment site through an access incision or internal body passage having a limited transverse dimension, e.g., through an incision less than two cm. in length. After the flexible sheet probe is folded in a tri-fold configuration 198 as shown in FIGURE 18, a suture 200 is used to restrain it, preventing flexible sheet probe 190
5 from prematurely unfolding prior to its placement at a treatment site.

FIGURES 19 and 20 illustrate how a flexible sheet probe 196' that is formed of a elongate quadrilateral-shaped flexible substrate is folded lengthwise into three layers and restrained for insertion to a treatment site within a patient's body. In FIGURE 19, a hairpin-shaped clip 204 is inserted over folded flexible
10 sheet probe 196' to restrain it in a tri-fold configuration 198'. Similarly, in the embodiment shown in FIGURE 20, a rectangular clip 206 having an internal opening sized to fit over tri-fold configuration 198' retains the folded state until the folded flexible sheet probe has been inserted into the treatment site.

FIGURE 21 illustrates how, having removed the restraint (i.e.,
15 hairpin-shaped clip 204 or rectangular clip 206), the flexible sheet probe is unfolded within a space 214 that is disposed between layers of tissue 210, to apply PDT or other medical treatment or diagnostic procedure to an adjacent tumor or lesion 212. As indicated in FIGURE 21, forceps 216 are used to grip opposite
20 ends of flexible sheet probe 196', thereby enabling it to be unfolded so that it overlies tumor or lesion 212.

Disposition of Flexible Probes at Various Treatment Sites

In FIGURES 22-28, use of a flexible sheet probe 220 is illustrated. Flexible sheet probe 220 comprises a flexible substrate 222, which includes light sources and/or other micro-electronic circuitry mounted thereon in contact with
25 conductive traces (none of which are shown). The flexibility of flexible sheet probe 220 facilitates its insertion in a treatment site inside a patient's body using a laparoscopic procedure. Flexible sheet probe 220 is preferably rolled into concentric cylindrical layers around a cylinder template 228. The roll of flexible substrate 222 is then restrained inside a sleeve 226, generally as shown in
30 FIGURES 22-25.

A push rod 240 is used to insert the rolled flexible sheet probe retained by sleeve 226 through a guide tube 238. The guide tube is surgically positioned so that it extends through a cutaneous or other tissue layer 232 to access an internal treatment site 230. In addition, an instrument guide 234 and a laparoscopic
35 tube 236 are inserted through cutaneous or other tissue layer 232 from opposite sides of guide tube 238 so that their distal ends are disposed adjacent treatment

site 230. Flexible sheet probe 220 will be deployed and unrolled to administer PDT or other medical therapy at treatment site 230.

In FIGURE 27, laparoscopes 241 are inserted through laparoscope tube 236 and guide tube 234. Forceps 244 are then used to grasp cylinder template 228 and sleeve 226 to enable the sleeve to be withdrawn from rolled flexible substrate 222. Push rod 240 is also withdrawn through guide tube 238. Eye pieces 242, which are provided on each of the two laparoscopes 241, enable the operator to manipulate rolled flexible substrate 222 and sleeve 226 during this procedure. Next, as shown in FIGURE 28, forceps 246 are inserted through guide tube 238 to grasp sleeve 226, withdrawing it from treatment site 230. In addition, laparoscopes 241 are used to unroll flexible substrate 222 at treatment site 230, thereby preparing it to administer PDT or other medical therapy. Although this step is not shown, forceps 246 are also used to withdraw template 228 through guide tube 238.

A cylindrical configuration for a flexible sheet probe 250 is shown in FIGURES 29-32. This embodiment comprises a flexible substrate 252 that is loosely rolled into a cylinder defining a passage 248 in the center of the cylinder through which fluids can readily flow when the flexible sheet probe is disposed within a body lumen. Disposed on an outer surface of flexible sheet probe 250 are a plurality of light sources 256, which are arranged in a closely spaced-apart array so that light emitted thereby irradiates the surface of a tumor (or other abnormal tissue) 258. Tumor 258 is disposed on the interior of a lumen 260. Lumen 260 may, for example, comprise a patient's esophagus or a blood vessel. A lead 254 conveys electrical current from a remote site, to energize the light sources and may optionally include additional conductors for conveying other signals to or from other types of micro-electronic circuitry mounted on flexible substrate 252.

In FIGURE 30, a flexible sheet probe 250' is illustrated that includes two loops 262 along one edge. Sutures 264 are passed through the loops in a laparoscopic or endoscopic procedure, to secure the flexible sheet probe fixed adjacent tumor 258 on the interior of lumen 260. Optionally, a restraint line 266 may be attached to the opposite end of flexible sheet probe 250', further securing the flexible sheet probe fixed at the treatment site within passage 260.

One of the advantages of flexible sheet probes 250 and 250' is their characteristic elasticity that causes them to expand outwardly to a larger diameter as tumor 258 shrinks in response to the PDT or other therapy provided by the flexible sheet probe. Consequently, the light sources (or other micro-electronic

circuits) mounted on flexible substrate 252 continue to remain in close proximity to the surface of the tumor as it contracts in response to the therapy.

In FIGURE 30A, a further alternative flexible sheet probe 250" is illustrated. This embodiment includes loops 268 formed on flexible substrate 252, so that the loops are disposed proximate to each other when the flexible substrate is elastically formed into a cylinder. A suture 270 connects loops 268 to restrain the flexible substrate in the relatively small diameter, cylindrical configuration for placement at an internal treatment site. Suture 270 is then cut, enabling the characteristic elasticity of flexible substrate 252 to increase the diameter of the cylindrical shape so that it conforms to the internal diameter at the treatment site.

In FIGURES 31 and 32, a flexible sheet probe 250'" is illustrated having a plurality of light sources (not shown) on its inner surface. This embodiment is intended for use in treating the external surface of a blood vessel 272 (or other organ lumen) about which cylindrical form 250'" is placed. Again, a restraint line 266 is optionally provided to hold the flexible probe in position at the treatment site, in opposition to an opposing force applied through lead 254. As shown in FIGURE 32, flexible sheet probe 250'" is formed into a tight cylindrical shape, which is the relaxed configuration of the flexible substrate. Because of the characteristic elasticity of the flexible substrate, the flexible sheet probe readily changes diameter to compensate for changes in the diameter of blood vessel 272 or other organ lumen about which its cylindrical shape is disposed. For example, as shown in FIGURE 32, blood vessel 272 has a larger diameter than it does in FIGURE 31, so that the overlap of opposite ends of flexible substrate 252 is less in FIGURE 32 for the larger diameter blood vessel than it is in FIGURE 31 for the smaller diameter blood vessel. As a result, the light sources or other electronic circuits mounted on the inner surface of the flexible sheet probe remain in intimate contact with the outer surface of the blood vessel as its diameter changes.

Turning now to FIGURE 33, yet a further flexible sheet probe 280 having a normal cylindrical shape is illustrated for use in applying PDT to a tumor or lesion 278 disposed on the inner surface of an esophagus 292, at a point immediately adjacent to a stomach 294. Fluids flowing through esophagus 292 readily pass through the center of flexible sheet probe 280 and into stomach 294. A plurality of light sources 286 are disposed in spaced-apart array on a flexible substrate 282 that comprises flexible sheet probe 280. An upper end of flexible substrate 282 includes a balloon cuff 284, which is used to secure flexible sheet probe 280 in place, to administer PDT to the tumor.

An opening in a wall 296 of stomach 294 is aligned with a corresponding opening through a cutaneous layer 298 for insertion of a gastrostomy tube 300. A restraint balloon 310, which is disposed at the inner end of the gastrostomy tube, holds it in place and retains wall 296 of the stomach in position against the inner surface of cutaneous layer 298.

5 Passing through gastrostomy tube 300 are fluid lines 302, 304, and 306. Fluid line 302 is used to supply compressed air to inflate restraint balloon 310. Fluid line 304 is coupled in fluid communication with balloon cuff 284 through a fluid line 290 that extends from the balloon cuff through stomach 294. The balloon cuff is inflated using compressed air conveyed through fluid lines 290 and 304. Fluid line 306 connects to an internal fluid line 308 within stomach 294 that is used for aspirating fluid from the stomach or for adding medicaments. In addition, a lead 288 conveys electrical power to flexible sheet probe 280 to energize light sources 286 and can also be used for conveying signals to and from other micro-electronic circuitry mounted on flexible substrate 282. A flexible sheet probe 280' is illustrated with balloon cuff 284 inflated in FIGURE 34, and with the balloon cuff deflated, in FIGURE 35.

FIGURES 36 and 37 illustrate an alternate approach for positioning flexible probe 100 at a gastroesophageal junction 318 to provide PDT to a tumor 320 that is disposed at that point. In this approach, flexible probe 100 is inserted through the nasal passage of a patient 314, threaded through the patient's esophagus 292, and positioned so that the light emitting sources 102 are disposed adjacent tumor 320.

Yet a further alternative embodiment for positioning a flexible probe 100' adjacent tumor 320 is illustrated in FIGURES 38 and 39. Flexible probe 100' includes a restraint line 322 that extends through a nasal passage 324, while a lead 316 extends from the interior of the patient's stomach through gastrostomy tube 300 to an external power supply 326. Restraint line 322 is encapsulated within the clear biocompatible sheath 106 of flexible probe 100'.

It may be desirable to treat tumors and lesions that are disposed inside either the small or large intestine of a patient. In FIGURE 40, an elastomeric bullet 330 is affixed to the distal end of flexible probe 100 using either a suture 332 or an elastic band that compresses the elastomeric bullet about the outer diameter of the flexible probe. Elastomeric bullet 330 has a substantially larger cross-sectional area than that of flexible probe 100, so that the natural peristalsis occurring within the small and large intestine advances the flexible

20

probe from the stomach to a desired treatment site in the bowel. Once the flexible probe reaches the treatment site, suture or elastic band 332 is cut using an endoscopic procedure, and the elastomeric bullet is carried through the intestine and exits the patient's body during a normal bowel movement or is extracted endoscopically.

5
10
15
20
25
30
35

With reference to FIGURE 41, a lead 316 connected to flexible probe 100 extends from the treatment site through the patient's large bowel 346 and small bowel 344, exiting stomach 294 through gastrostomy tube 300. To ensure that flexible probe 100 remains fixed at the treatment site where a tumor or lesion 352 is disposed on the internal surface of large bowel 346, loops 348 are attached with sutures 350 to the tissue of the bowel. An endoscope or colonoscope is employed to place the sutures.

A disadvantage of the approach illustrated in FIGURE 41 is the relatively long length required for lead 316, which must extend from the treatment site disposed near the lower end of large bowel 346 into stomach 294. The total length of lead 316 may easily exceed 25-30 feet. In FIGURE 42, an alternative approach is shown, which employs a Bishop-Koop procedure to create an enterocutaneous fistula by transecting large bowel 346 at a point immediately above and adjacent to tumor 352. Sutures 356 are placed to connect the lower portion of the bowel to a new opening 354 made in the wall of the upper portion of the large bowel, adjacent the transection in the upper portion of the large bowel. A transected end 358 of the upper portion of the large bowel is then attached by sutures 360 to an opening 362 in abdominal wall 340, thereby enabling a relatively short lead 316 to exit the patient's body. Waste matter passing through large bowel 346 will continue to be moved through both sections of the transected bowel by peristalsis.

A flexible probe 370 having loops 376 disposed at each end is shown in FIGURE 43. This embodiment illustrates an application in which the flexible probe is helically coiled around an artery 380 and secured at each end with sutures 378 that fasten loops 376 to adjacent tissue. A lead 372 extends from one end of the flexible probe to a power supply 374. Flexible probe 370 can thus be used, for example, in applying PDT to treat arteriosclerotic deposits inside artery 380 within the region about which the flexible probe is coiled. Light emitted by the light sources in the flexible probe is transmitted through the wall of the artery and absorbed by photoreactive dye-perfused arteriosclerotic deposits, causing the deposits to breakdown.

21

A flexible sheet probe 390 is shown in FIGURE 44 for use in effecting PDT treatment of a congested coronary artery 398. The four corners of flexible sheet probe 390 are sutured to the pericardium lining around a heart 396 so that a flexible substrate 392 is disposed inside the pericardium lining. Since the pericardium lining is opaque and does not readily transmit light, the pericardium lining must be incised so that the flexible sheet probe can be disposed adjacent the coronary artery being treated and molded around the curved surface of the heart. Light emitted by the light sources mounted on the flexible probe thus passes into the interior of the coronary artery. A lead 394 extends from flexible substrate 392 to a remote power source that supplies electrical current to energize the light sources. FIGURE 45 illustrates arteriosclerotic deposits 402 in a blood vessel or coronary artery that may be treated using PDT administered with the present invention.

FIGURES 64 through 66 illustrate a method and apparatus for implanting and fixing flexible probe 100 within a tumor 654 (or other abnormal tissue) comprising a treatment site within a patient's body. Although flexible probe 100 is illustrated in these Figures as an example of one type of flexible probe useful in effecting this aspect of the invention, it will be apparent that other types of flexible probes that include a strip of flexible substrate that is relatively long compared to its transverse dimension can be used instead.

As shown in FIGURE 65, a curved surgical needle 650 is forced through normal tissue 656 and along a curved path through tumor 654. This curved path defines a desired position for a flexible probe to be disposed to administer PDT or some other medical procedure or therapy. In the disclosed example, flexible probe 100 is connected to curved surgical needle 652 and drawn along after the needle along the curved path defined by the passage of curved surgical needle's sharp point through normal tissue 656 and tumor 654. Although not illustrated in the Figure, a straight surgical needle can alternatively be used. At a point where the distal end of the flexible probe exits through a surface of tissue (possibly inside the patient's body), curved surgical needle 650 is detached from flexible probe 100 and withdrawn. Since this procedure may be accomplished endoscopically, the curved surgical needle may be withdrawn either through a natural body opening or through an incision. It is also contemplated that the distal end of flexible probe may exit the patient's body through a cutaneous layer. In either case, the main body of the flexible probe is thus disposed in a desired

22

position at a treatment site, with leads 118 extend to another position either inside or outside the patient's body.

Instead of directly coupling the flexible probe to the surgical needle, a line (e.g., a suture) may be coupled to the proximal end of the surgical needle and drawn into the treatment site along the path created by the surgical needle in the tissue. One end of the line is then attached to the flexible probe and the other end of the line is pulled to advance the flexible probe along the path through the tissue and into the treatment site. This technique is not separately illustrated, since it should be apparent from an examination of FIGURE 65. The line simply serves as an intermediary element to draw the flexible probe into the treatment site after the surgical needle has defined the path that will be followed and has drawn the line into position to advance the flexible probe.

If the flexible probe is to remain at the treatment site for an extended period of time, e.g., for several days or longer, it will normally be necessary to take steps that ensure the flexible probe does not move relative to the treatment site, but instead remains fixed in the desired position to administer the medical treatment. Accordingly, as shown in FIGURES 64 and 66, a disk-shaped button 660 having a hollow sleeve 662 extending outwardly from the center of one surface of the button is attached to the distal end of flexible probe 100. Preferably button 660 is made of a biocompatible and elastomeric polymer plastic. The flexible probe is inserted inside hollow sleeve 662 and secured with a suture 666, which compresses the hollow sleeve around the flexible probe. Button 660 may also be inverted, so that sleeve 662 extends distally of the button's disk-shaped surface. Alternatively, the distal end of the flexible probe may be secured inside the hollow sleeve by crimping the hollow sleeve (so that friction between the inside surface of the hollow sleeve and the outer surface of the flexible probe provides the attaching force), or adhesively coupled thereto with a suitable biocompatible adhesive. Although not shown in the drawings, sleeve 662 may further alternatively be connected to the flexible probe using a threaded fastener, e.g., a set screw, or with a pin that extends through the sleeve and into the flexible probe. The diameter of button 660 is greater than the diameter of flexible probe 100, so that the distal end of flexible probe 100 is prevented from moving back into tissue 656 by the button. In addition, button 660 includes two orifices 664 disposed just inside its outer circumference. Sutures 668 are passed through one or both of these orifices to couple button 660 to tissue 656, prevent

23

movement of the distal end of flexible probe 100. Alternatively, button 660 may be adhesively attached to tissue 656, using a suitable biocompatible adhesive.

Furthermore, as shown in FIGURE 66, a disk-shaped button 670 having a hollow sleeve 672 extending outwardly from the center of one surface of the button may be attached to the proximal end of flexible probe 100. Button 670 is generally similar to and is made of the same plastic material as button 660. However, since leads 118 extend from the proximal end, an opening 676 is formed in the center of button 670 and leads 118 pass through the opening and extend to a remote location. Button 670 is attached to the proximal end of flexible probe 100 using a suture 674 (or by crimping the hollow sleeve of button 670 around leads 118 or flexible probe 100, or by use of a suitable adhesive). It is again contemplated that a threaded fastener, or a pin (neither shown) may be used to secure the sleeve to the proximal end of the flexible probe. Button 670 is secured to adjacent tissue 656 using sutures 678 that pass through orifices 664 formed in the button, adjacent its circumference. Again, button 670 may be inverted so that its sleeve extends proximally of the button's disk-shaped surface.

By attaching either or both buttons 660 and 670 to flexible probe 100, the flexible probe is fixed in the desired position at the treatment site and prevented from moving. Although the figures illustrate a preferred embodiment in which disk-shaped buttons 660 and 670 are employed, it will be apparent that objects having other shapes can be attached to one or both ends of a flexible probe to secure it in place in a desired position at a treatment site. The objects in this embodiment preferably have at least one transverse dimension that is greater than a cross sectional size of the flexible probe and/or be secured to the adjacent tissue to prevent movement of the flexible probe relative to the tissue inside the patient's body. Thus, instead of disk-shaped buttons 660 and 670, a rectangular or bar-shaped object (not shown) could be employed to achieve the same function. It is also contemplated that a patch of flexible material, e.g., generally like button 660 or 670 but more flexible and without a sleeve, may be attached to the lead or flexible probe and sutured or adhesively affixed to the surface of the tissue.

Fabricating Flexible Probes

For manufacturing flexible probes that are elongate, such as flexible probes 100 and 108, a plurality of strips of flexible substrate are preferably produced from a larger flexible substrate 412, as shown in FIGURE 46. In an initial prototype of the present invention, the overall outer dimensions of the flexible substrate are approximately 3.9" x 4.6"; however, these dimensions are

24

not in any way limiting, since the flexible substrate can be made in almost any size desired. A plurality of pairs of parallel conductive traces 414a and 414b are applied to the surface of flexible substrate 412 using conventional photolithography techniques, defining a plurality of flexible substrate strips 410 that can be cut from flexible substrate 412 after light emitting sources or other micro-electronic circuitry are mounted thereon. In the initial prototype of the present invention, the flexible traces comprise a layer of wire bondable soft gold electroplate about 0.00003" thick over a layer of sulfamate nickel electroplate about 0.0001" thick, over one ounce copper that is applied to the polyimide film comprising the flexible substrate. While substantially narrower conductive traces can readily be formed, conductive traces 414a and 414b in the prototype are about 0.025" wide and are spaced about 0.005" apart. Other techniques for producing conductive traces that are flexible and other materials comprising the conductive traces can alternatively be used to make the present invention, as are well known in the prior art. Examples of prior art flexible circuit laminates and procedures for making the flexible circuit laminates and applying conductive traces are disclosed in U.S. Patent Nos. 4,647,508 and 4,634,631 (Gazit et al.), which are assigned to Rogers Corporation.

In FIGURE 47, a flexible substrate strip 410 is illustrated (enlarged), wherein a plurality of spaced-apart "Xs" mark locations for mounting the light emitting sources or other micro-electronic circuits on conductive traces 414a and 414b. It is also contemplated that additional conductive traces may be provided for more complex electronic circuitry, for example, to convey signals and for interconnections, as is well known to those of ordinary skill in the art.

A line 416 disposed in the middle of flexible strip 410 indicates where the strip is to be either cut or folded to create the flexible probe shown in FIGURE 48. In this flexible probe, a plurality of LEDs 418 are attached to conductive traces 414a on flexible substrate 412, which is cut on line 416. The two portions of the flexible substrate are then bonded together (back-to-back) to create a double thick flexible substrate. Fly wires 420 connect terminals 424 on LEDs 418 to conductive traces 414b. The fly wires are preferably ultrasonically bonded, but may alternatively be soldered, or otherwise attached to terminals 424 and conductive traces 414b. Conductive epoxy 422 adherently attaches the other terminals of LEDs 418 to conductive traces 414a, as shown in FIGURE 49. Transparent flexible envelope 106 encloses the assembly, protecting LEDs 418 and fly wires 420 from damage as the flexible probe is flexed or bent during use.

25

Yet another configuration for a flexible probe 460 is illustrated in FIGURE 53. In this configuration, light sources 470 (or other micro-electronic circuitry), are mounted between conductive traces 466 and 468 that are applied to the surface of flexible substrate strips 462. The conductive traces are adherently secured to terminals on the light sources (or other types of micro-electronic circuitry) by conductive epoxy layers 472, as shown in FIGURE 54. A transparent, biocompatible flexible polymer envelope 464 protects the assembly and provides additional strength. Light emitted by light sources 470 passes through flexible substrate strips 462 and through envelope 464.

A serpentine flexible sheet probe 480 is illustrated in FIGURE 55. In this embodiment, a pair of conductive traces 488 and 490 define two serpentine paths that are generally equidistant from each other and are applied to a flexible substrate 482. Leads 484 and 486 respectively connect to the conductive traces so that electrical current can be supplied to energize light sources 492. As shown in FIGURE 56, fly wires 494 electrically couple light sources 492 to conductive traces 488. The light sources are also adhesively and electrically connected to conductive traces 490. The resulting flexible sheet is encapsulated within an envelope of a clear biocompatible polymer material 496, as indicated by the dash lines surrounding the flexible substrate and light source.

Referring now to FIGURES 57 and 58, an alternative approach for coupling a light sources (or other type of electronic microcircuit) to conductive traces 504 and 506 that are applied to a flexible substrate strip 502 is illustrated. In this approach, the light sources preferably comprise two different types of LEDs 508 and 508' that emit light having different characteristic wavebands, e.g., 640 nm peak and 720 nm peak, respectively. The LEDs are mounted on the flexible substrate strip, between conductive traces 504 and 506, with terminals on the LEDs disposed immediately adjacent one of the conductive strips. Although only one LED 508' is shown, it will be understood that LEDs 508 alternate with LEDs 508' along the flexible substrate strip. Alternative configurations for mounting the two types of LEDs are clearly contemplated, for example, mounting two LEDs 508, followed by two LEDs 508' along the flexible substrate strip, and various patterns or arrays of the different LEDs can be provided on flexible substrate sheets.

A fly wire 510 connects a terminal 514 disposed on one side of each LED 508 to conductive trace 506, and a drop of conductive epoxy 512 connects the terminal on the opposite side of each LED 508 to conductive trace 504.

26

Alternatively, a corresponding drop of conductive epoxy may be used in lieu of fly wire 510 to connect terminal 514 to conductive trace 506. Similarly, fly wire 510 (or a drop of conductive epoxy) connects terminal 514 disposed on light source 508' to conductive trace 504, and drop of conductive epoxy 512 connects the opposite side terminal of light source 508' to conductive trace 506. Thus, the polarities of the terminals on LEDs 508 are opposite those of LEDs 508'. Consequently, for a particular polarity of voltage applied between conductive traces 504 and 506, only one of the two different types of LEDs are energized to emit light at the characteristic waveband of that type of LED. Accordingly, by selecting the polarity of the voltage applied to energize the LEDs, the waveband of LEDs 508 or 508' can be selected. The other type of LEDs will not be energized until the applied voltage polarity is reversed. An advantage of this configuration is that PDT can be selectively administered with light at one of two different wavebands. Two different photoreactive agents that absorb light at the characteristic wavebands of LEDs 508 and 508' will typically be applied to the treatment site to enable the medical practitioner controlling the PDT to select the waveband that appears most effective in the treatment. Just as a plurality of chemotherapy regimens are often more effective in destroying cancerous tissue, a plurality of different wavebands may prove more effective in PDT of abnormal tissue. The practitioner may select the more effective waveband or may elect to administer light at alternating wavebands to the treatment site.

Preferably, flexible substrate strip 502 is transparent to light emitted by LEDs 508 and 508'. Although not shown, this embodiment will typically be enclosed in a transparent biocompatible polymer envelope, just as the other embodiments described above are.

In FIGURE 59, details of a flexible sheet probe 520 are illustrated. In this embodiment, a flexible substrate comprising a generally planar and quadrilateral-shaped sheet is provided with a plurality of conductive traces 524 and 526, as pairs of strips that extend generally parallel to each other across a flexible substrate 522. All of the strips comprising conductive traces 524 are electrically connected to a lead 528, and all of the strips comprising conductive traces 526 are electrically connected to a lead 530. Depending upon the spacing between conductive traces 524 and 526, the various techniques shown above can be used for mounting light sources or other types of micro-electronic circuitry to the pairs of conductive traces. After such devices are mounted and electrically

27

connected to the conductive traces, the flexible substrate probe is enclosed within a transparent, biocompatible polymer envelope 532.

To focus light emitted from light sources mounted on any of the flexible probes described above, it is contemplated that a reflector 544 can be mounted within or adjacent to each light source 542, as shown in FIGURE 60, to facilitate reflecting or focusing light emitted by the light source. In this Figure, conductive epoxy adhesively mounts light source 542 and reflector 544 to conductive trace 524 and provides an electric path between the terminal of the light source and the conductive trace. Similarly, a fly wire 548 electrically connects the other terminal of the light source to conductive trace 526. It is also contemplated that a reflective surface can be fabricated within the light source, to facilitate focusing light emitted by the light source.

Flexible Probe System

As noted repeatedly above, flexible probes made in accordance with the present invention can be used for other purposes, but are primarily disclosed in connection with providing PDT. In FIGURE 50, LEDs or other types of light source(s), and/or other types of micro-electronic circuits are provided electrical current to energize the devices through power leads 316 from a power supply 326, which may be either remotely located outside the patient's body, may comprise a battery mounted on/adjacent the flexible probe or at a remote site within the patient's body, or may be coupled electromagnetically or through an RF signal, to an external source of power. It is also contemplated that power can be supplied from an external IR light source (not shown) producing IR light that passes through the cutaneous layer and is converted by an IR detector (not shown) into electrical current supplied to the flexible substrate. FIGURE 50 is a block diagram generally illustrating the flexible probe system.

In FIGURE 51, flexible probe 100 is shown with leads 316 that are intended to extend outside the patient's body and thus terminate in connectors 428 for direct connection to an external power supply 326. However, as noted above, electrical power and signals can be conveyed between the flexible probe and an external device, across a cutaneous layer 452 and without a direct connection, as illustrated in FIGURE 52. In this Figure, an LED array 436 and photodetectors 438 are mounted on a flexible probe 440. The flexible probe is directly connected to a rectifier 434. Rectifier 434, an optional rechargeable battery 435, a receiver coil array 430, a driver circuit 442, and a telemetry transmitter 444 are preferably disposed together within the patient's body, apart

from the treatment site. Rectifier 434 is electrically connected to receiver coil array 430 and full-wave rectifies alternating current output from the receiver coil array, producing electrical current that may be used to charge optional rechargeable battery 435. If rechargeable battery 435 is used, the power stored therein is subsequently supplied to the flexible probe to energize the light source(s), and/or other micro-electronic circuitry mounted thereon. Receiver coil array 430 includes at least one receiver coil (not shown) that is energized by electromagnetic or RF energy transmitted from an external power coil 448 disposed outside the patient's body, adjacent cutaneous layer 452, opposite receiver coil array 430. Electrical energy is supplied to power coil 448 from a power supply 450. The power supply is energized from a conventional 60 Hz, 120 volts alternating current line (not shown).

Photodetectors 438 are included on flexible probe 440 to monitor the fluorescence by cells treated with a photoreactive agent at a treatment site, to determine whether additional photoreactive agent should be added to the treatment site and/or to determine the efficacy of the PDT. The extent of such fluorescence is a function of the amount of photoreactive agent absorbed by abnormal cells, and if recently perfused into the treatment site, indicates the extent of abnormal cells remaining. The photodetectors mounted on a second flexible probe (not shown) disposed on an opposite side of the treatment site from that at which a flexible probe comprising a light source can also be used to monitor light transmission through the treatment site to determine the amount of photoreactive agent present and to monitor the efficacy of the system in applying the PDT.

Signals developed by photodetectors 438 are conveyed to a driver circuit 442, which provides a suitable signal to drive telemetry transmitter 444. In response to the drive signal, telemetry transmitter 444 produces an RF signal that is indicative of the output from the photocells mounted on the flexible probe. The RF signal developed by telemetry transmitter 444 is conveyed across cutaneous layer 452 to an external telemetry receiver 446, which indicates the level of the signal to an operator.

For embodiments of the flexible probe in which it is preferable to provide power for the light sources or other micro-electronic circuits mounted on the flexible probe through electromagnetic coupling, as opposed to directly through leads that extend externally outside the patient's body, either of two types of coils can be used, as shown in FIGURES 61 and 62. In FIGURE 61, a receiver coil 552 comprises a plurality of turns of conductive lead 554. Receiver coil 552 can be located at some

29

distance from the treatment site within the patient's body, and is disposed immediately under and adjacent a cutaneous layer 550. To provide electrical energy to the flexible probe disposed at the treatment site, a transmitter coil 556 comprising a number of turns of a conductive lead 558 that is connected to an external power supply (not shown in FIGURE 61) is disposed on the outer surface of cutaneous layer 550, immediately adjacent receiver coil 552. An alternating current applied by the external power supply develops an electromagnetic field in transmitter coil 556 that couples to receiver coil 552, causing a corresponding alternating current to flow in the receiver coil. This alternating current is rectified using a full wave rectifier (such as rectifier 434 shown in FIGURE 52), which may be included within the flexible probe, or alternatively, disposed at receiver coil 552.

In a related scheme, a transmitter coil 580 comprising a ferrite core 582 (or a core of another material having a relatively high magnetic permeability) that is generally "C"-shaped is coupled through leads 558 to an external power supply (not shown), which supplies an alternating current to helical conductive coils 584 that are wrapped around a ferrite core 582. The alternating current flowing through conductive coils 584 develops an electromagnetic field that is coupled to a receiver coil 590. Receiver coil 590 is disposed immediately opposite transmitter coil 580, inside the patient's body, under cutaneous layer 550. Receiver coil 590 also comprises a C-shaped ferrite core 592, around which is helically coiled a conductor 594, which is coupled to leads 554 to convey electrical current to the remotely located flexible probe that is disposed at the treatment site within the patient's body. Transmitter coil 580 and receiver coil 590 are oriented with their respective ferrite cores 582 and 592 aligned, so as to maximize flux linkage between the ferrite cores. These coils are substantially more efficient at transferring electromagnetic energy than transmitter coil 556 and receiver coil 552, since the latter are limited by the relatively low magnetic permeability of air rather than the much greater magnetic permeability of the ferrite cores.

It is contemplated that various other configurations and arrays of transmitter and receiver coils can be used to supply power to energize the electronic components inside the patient's body and mounted on the flexible probe. It is also contemplated that the receiver coil can be mounted on the flexible probe in those cases where the treatment site is disposed immediately adjacent cutaneous layer 550.

FIGURE 63 illustrates a panel 604 of infrared LEDs 606 that is disposed against the external surface of cutaneous layer 550. Infrared LEDs 606 are energized with electrical current from the external power supply through leads 558.

30

Immediately adjacent panel 604, inside cutaneous layer 550, is disposed a panel 600 of infrared sensitive photovoltaic cells 602. In response to the infrared light received from panel 604, photovoltaic cells 602 produce an electrical current that is supplied to the flexible probe (or a storage battery) through leads 554.

- 5 Although the present invention has been described in connection with the preferred form of practicing it, those of ordinary skill in the art will understand that many modifications can be made thereto within the scope of the claims that follow. Accordingly, it is not intended that the scope of the invention in any way
- 10 be limited by the above description, but instead be determined entirely by reference to the claims that follow.

31

The invention in which an exclusive right is claimed is defined by the following:

1. A method for implanting and fixing a flexible probe in a desired position at a treatment site within a patient's body, comprising the steps of:
 - (a) providing a flexible probe that comprises an elongate strip having sufficient flexibility to sustain deformation and bending without damage;
 - (b) attaching the strip to a surgical needle;
 - (c) forcing the surgical needle through tissue to the treatment site within the patient's body, so that the strip comprising the flexible probe is drawn into the tissue by the surgical needle, along a path followed by the surgical needle;
 - (d) once the strip is implanted with the surgical needle in the desired position at the treatment site, disconnecting the surgical needle from the strip; and
 - (e) withdrawing the surgical needle from the tissue, leaving the strip disposed in the desired position within the patient's body to administer the medical treatment to the treatment site.
2. The method of Claim 1, further comprising the step of securing one end of the strip to a first object, said first object serving to anchor the strip in the desired position at the treatment site, preventing movement of the strip relative to the treatment site.
3. The method of Claim 2, further comprising the step of securing another end of the strip to a second object, said second object further serving to anchor the strip in the desired position at the treatment site, preventing movement of the strip relative to the treatment site.
4. The method of Claim 2, further comprising the step of securing the first object to a tissue surface in the patient's body.
5. The method of Claim 3, wherein the second object includes a sleeve that slips over the strip and a lead that is coupled to the strip, further including the step of securing the second object to the strip after the strip is disposed at the desired position.

32

6. The method of Claim 5, wherein the steps of securing the second object comprises one of the steps of: crimping the sleeve of the second object about the strip, adhesively connecting the second object to the strip, connecting the second object to the strip with a threaded fastener, connecting the second object to the strip with a pin that extends through the sleeve and into the strip, and suturing the second object to the strip.

7. The method of Claim 1, wherein the step of forcing the surgical needle includes one of the steps of: grasping the surgical needle with a needle holder, and pulling the surgical needle into the desired position with forceps.

8. A medical procedure for implanting and stabilizing a flexible probe at a desired position within a patient's body, said flexible probe being used for effecting a medical treatment at a treatment site proximate the desired position, comprising the steps of:

- (a) providing a strip of a flexible substrate on which is disposed a device for effecting the medical treatment, said strip having a cross-sectional dimension, and a length, said length of the strip being substantially greater than its cross-sectional dimension;
- (b) coupling a distal end of the strip to a pointed instrument;
- (c) forcing the pointed instrument through tissue in the body of the patient, so that the pointed instrument draws the strip after it into the desired position at the treatment site;
- (d) decoupling the strip from the pointed instrument; and
- (e) withdrawing the pointed instrument from the patient's body, leaving the strip and the medical device disposed at the desired location to administer the medical treatment.

9. The method of Claim 8, further comprising the step of securing the strip so that it does not move from the desired position.

10. The method of Claim 9, wherein the step of securing comprises the step of coupling an object having a relatively larger cross-sectional size than the strip to at least one end of the strip.

33

11. The method of Claim 9, wherein the step of securing comprises the step of coupling an object having a relatively larger cross-sectional size than the strip to both ends of the strip.

12. The method of Claim 9, wherein the step of securing comprises the step of coupling the strip to the strip using one of an adhesive, a crimped sleeve, a threaded fastener, a pin, and a suture.

13. The method of Claim 8, wherein the pointed instrument comprises a surgical needle.

14. The method of Claim 8, further comprising the steps of passing a lead from the strip through an opening in an object; and fastening the object to the lead to secure the strip in the desired position, said lead extending proximally beyond the object to a different location.

15. The method of Claim 8, wherein a distal end of the strip is secured to an object that is disposed against a tissue surface to prevent movement of the strip from the desired position at the treatment site.

16. Apparatus for administering a medical procedure to a treatment site disposed within a patient's body, comprising:

(a) a flexible strip having a width and a length, said width being substantially less than said length of the flexible strip, a medical device being disposed on the flexible strip for effecting the medical procedure at the treatment site;

(b) a pointed instrument for defining a path through the tissue in the patient's body, said path being used for delivering the flexible strip to the treatment site in the patient's body; and

(c) means for drawing the flexible strip along the path through tissue in the patient's body so that the flexible strip is disposed in a desired position at the treatment site.

17. The apparatus of Claim 16, further comprising an object attachable to the flexible strip, said object being attached to at least one end of the flexible strip after the flexible strip is introduced to the treatment site, to secure the flexible strip in the desired position, preventing the flexible strip from moving away from the desired position.

34

18. The apparatus of Claim 16, wherein the object includes a sleeve that is sized to fit over an end of the flexible strip and to be secured thereto.

19. The apparatus of Claim 18, wherein the sleeve is secured to the flexible strip by one of a crimp of the sleeve, an adhesive, a threaded fastener, a pin that extends through the sleeve, and a suture.

20. The apparatus of Claim 18, wherein the object includes an opening, and wherein the flexible strip is attached to a lead that extends from the flexible strip to another location, said lead passing through the opening in the object and being secured to the object to prevent movement of the flexible strip away from the desired position.

21. The apparatus of Claim 16, wherein the pointed instrument comprises a surgical needle.

22. A method for implanting and fixing a flexible probe in a desired position at a treatment site within a patient's body, comprising the steps of:

- (a) providing a flexible probe that comprises an elongate strip having sufficient flexibility to sustain deformation and bending without damage;
- (b) forcing a pointed instrument through tissue to the treatment site within the patient's body, creating a path through the tissue;
- (c) drawing the strip comprising the flexible probe into the tissue, along the path followed by the pointed instrument; and
- (d) once the strip is implanted at the treatment site, administering the medical treatment to the treatment site.

23. The method of Claim 22, wherein a line is coupled to the pointed instrument so that the line is drawn through the tissue behind the pointed instrument and extends behind the pointed instrument along the path followed thereby, wherein the step of drawing the strip comprises the step of coupling the strip to the line and pulling the line along the path through the tissue to advance the strip into the treatment site.

24. The method of Claim 22, wherein the strip is coupled to the pointed instrument and is drawn into the treatment site as the pointed instrument is advanced.

1/27

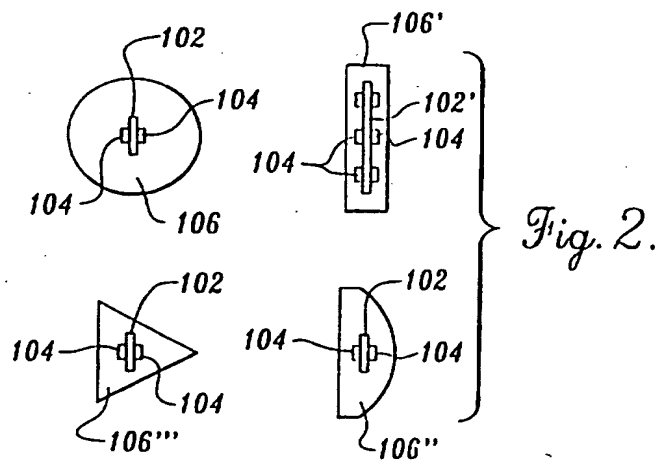
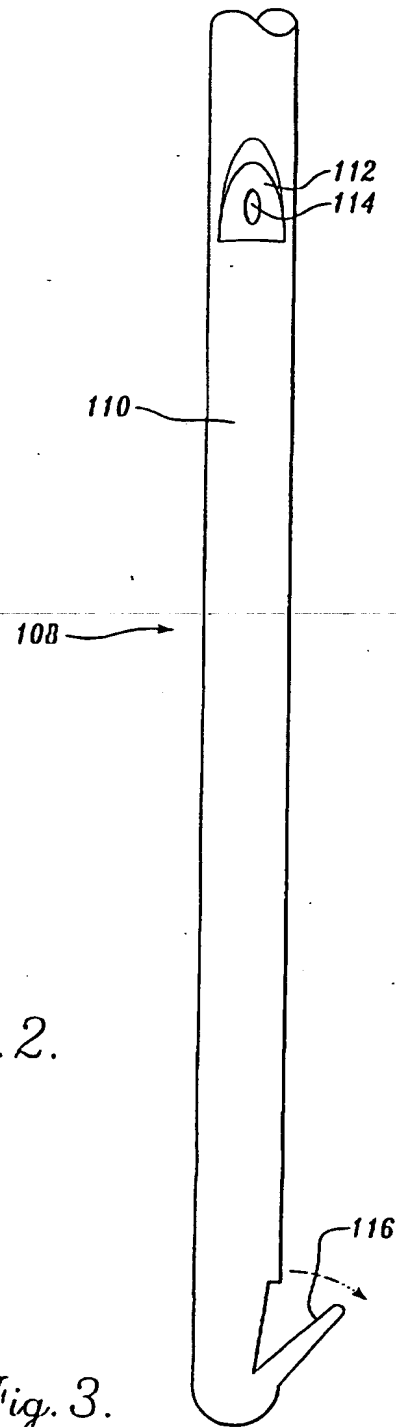
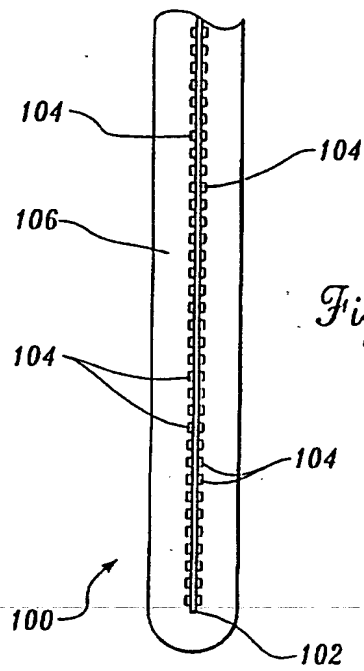

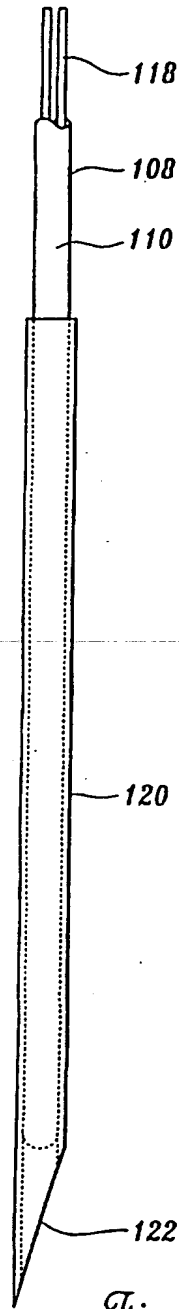

Fig. 4.

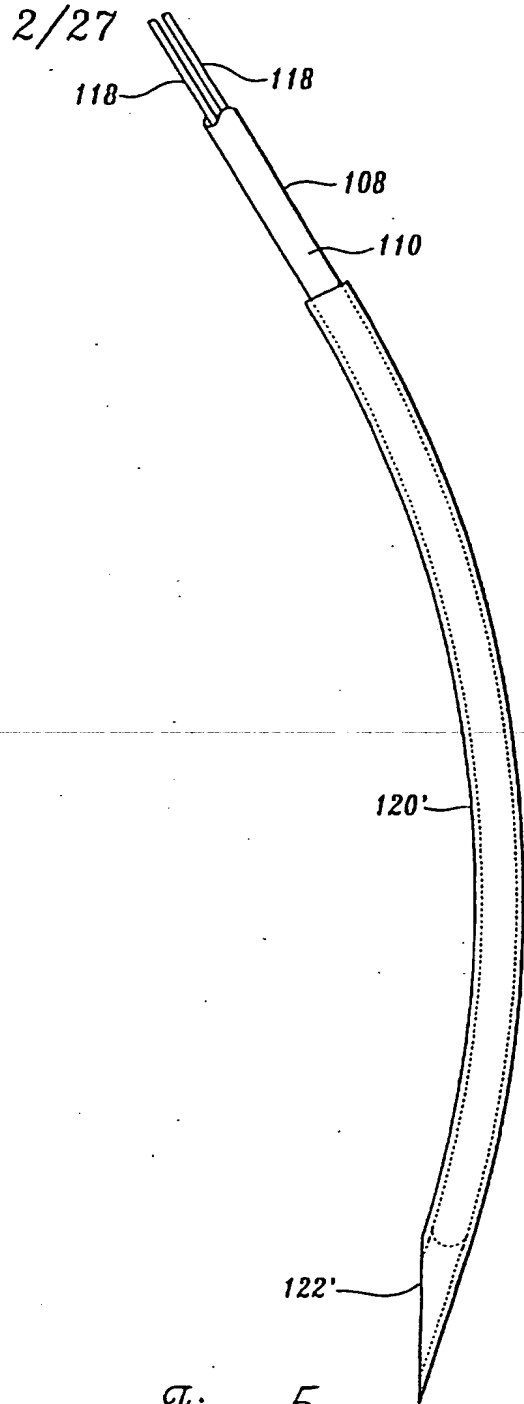

Fig. 5.

3/27

Fig. 6A.

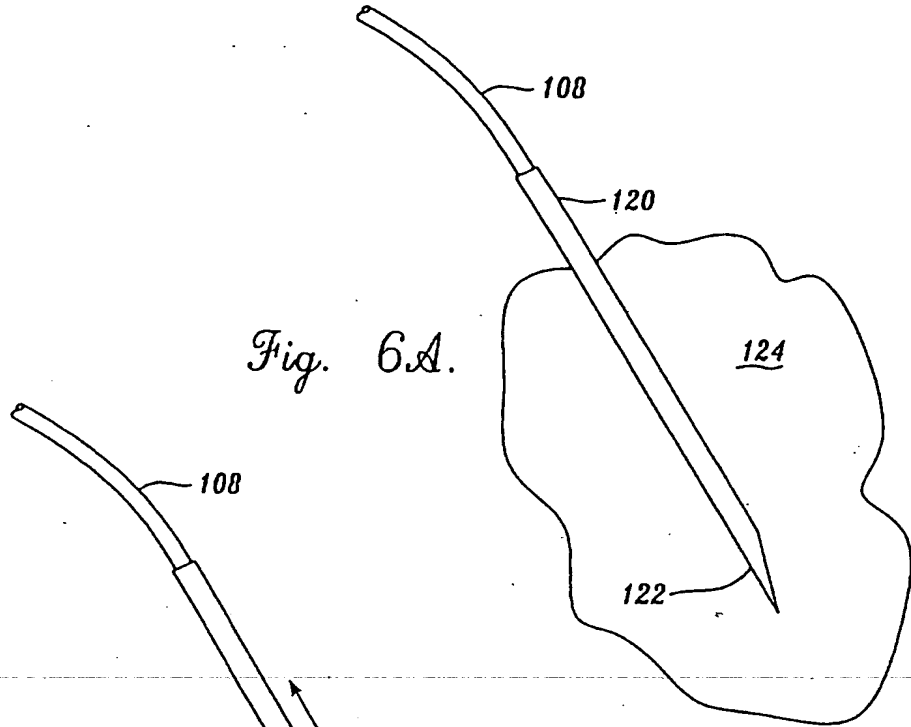
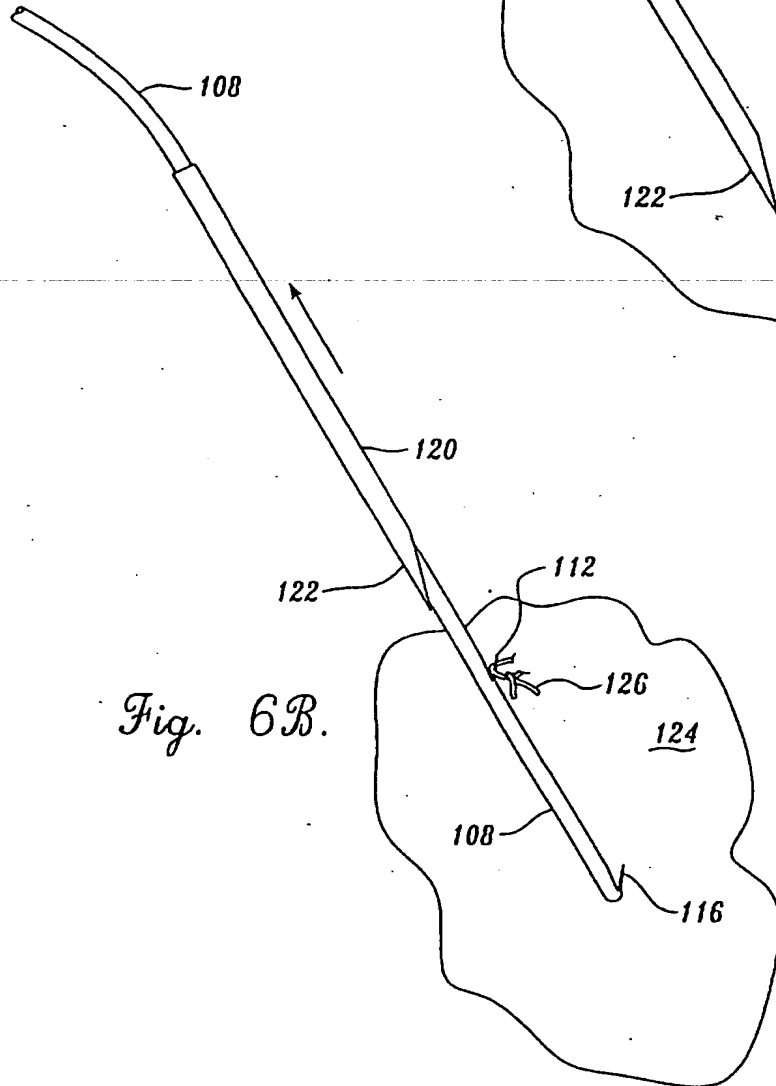

Fig. 6B.



4/27

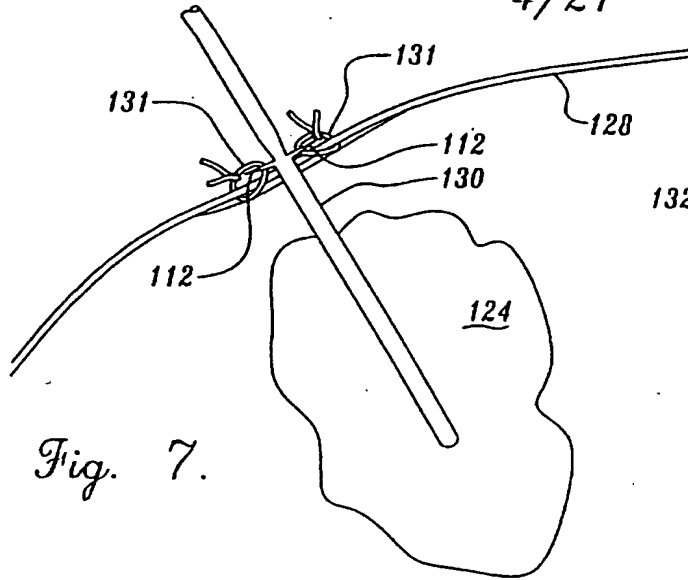

Fig. 7.

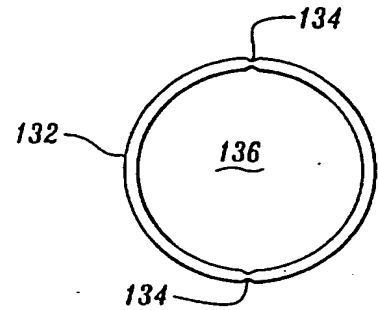

Fig. 9.
(PRIOR ART)

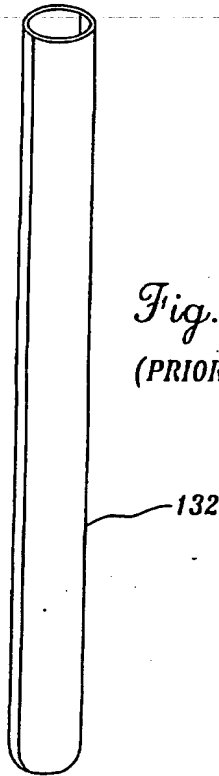

Fig. 8.
(PRIOR ART)

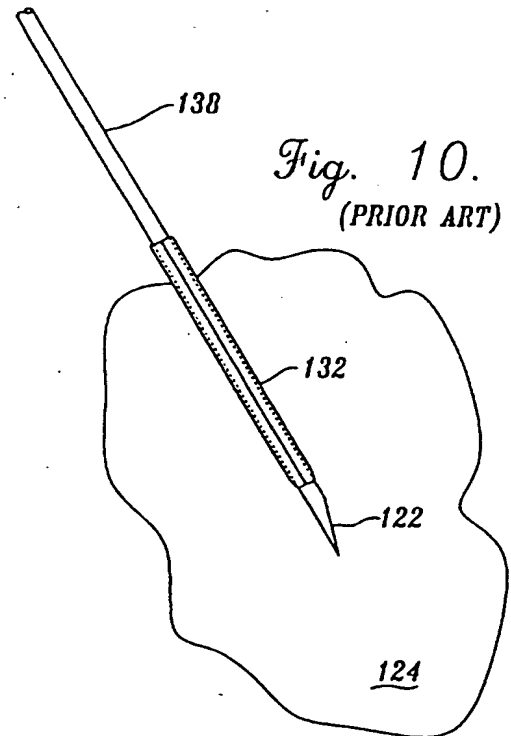
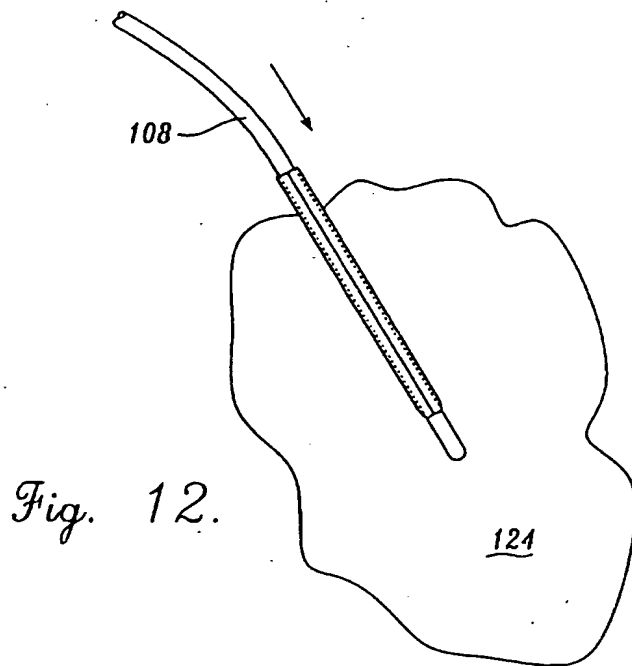
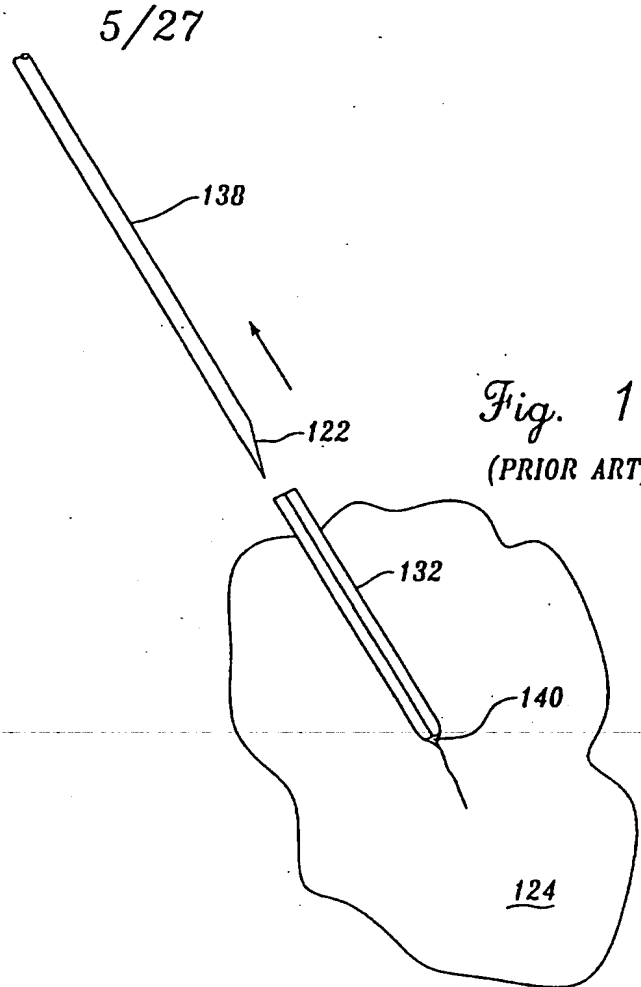

Fig. 10.
(PRIOR ART)



6/27

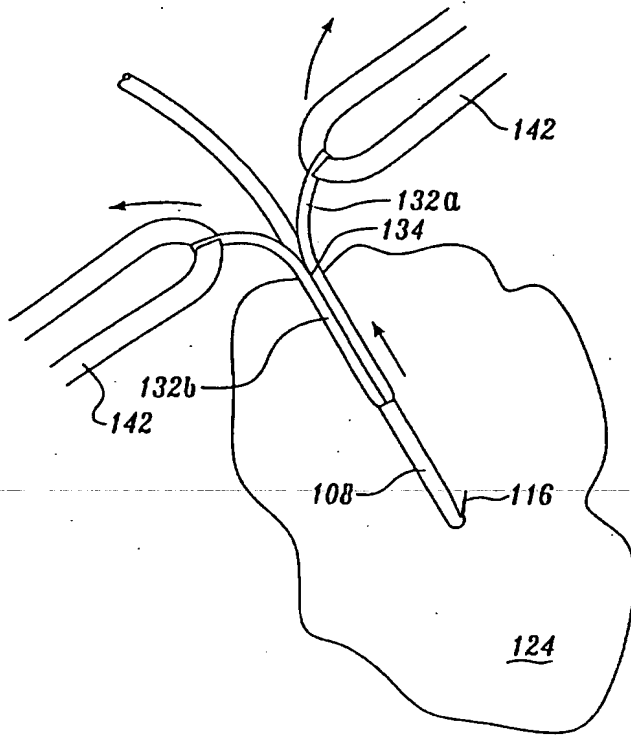
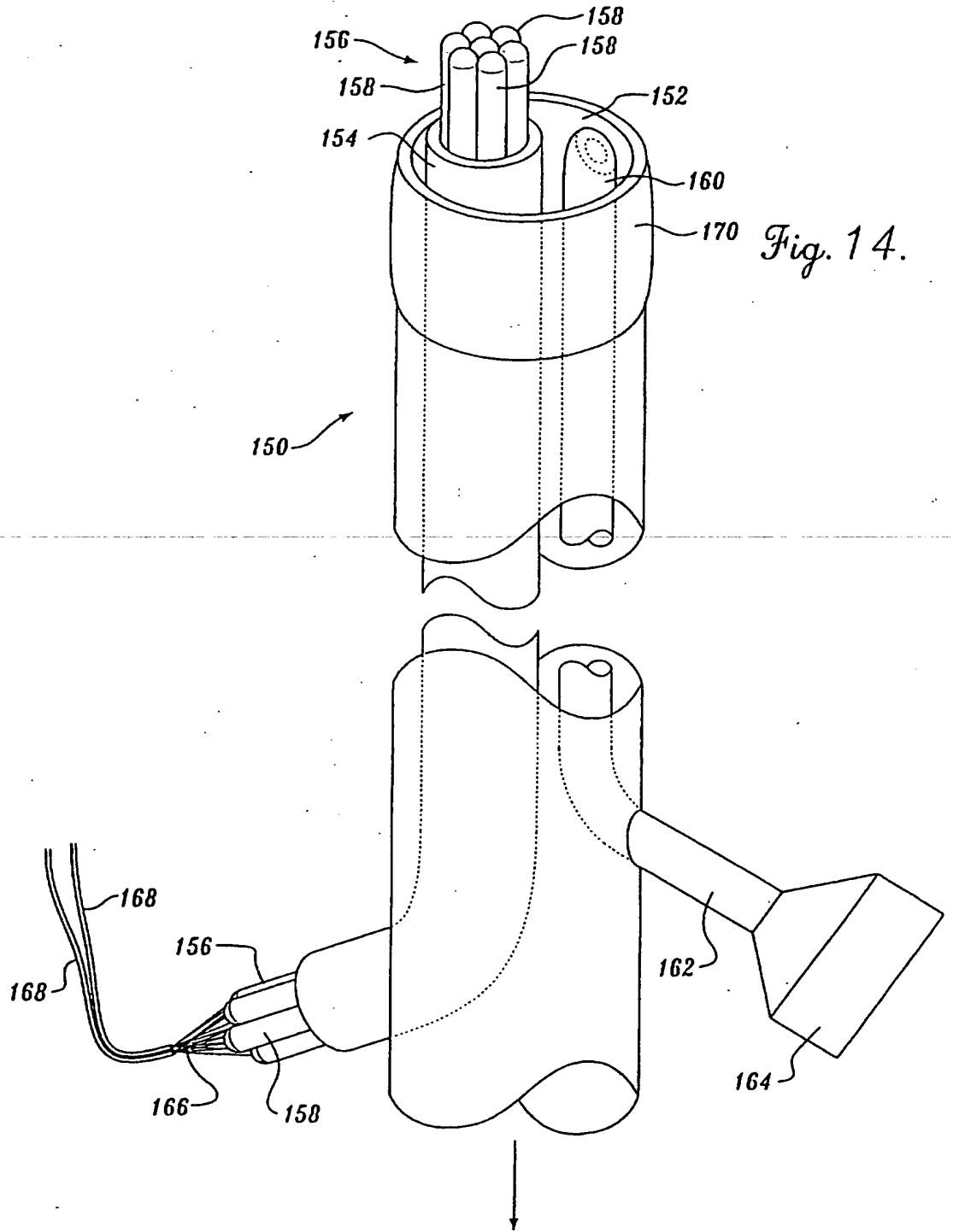

Fig. 13.

7/27



8/27

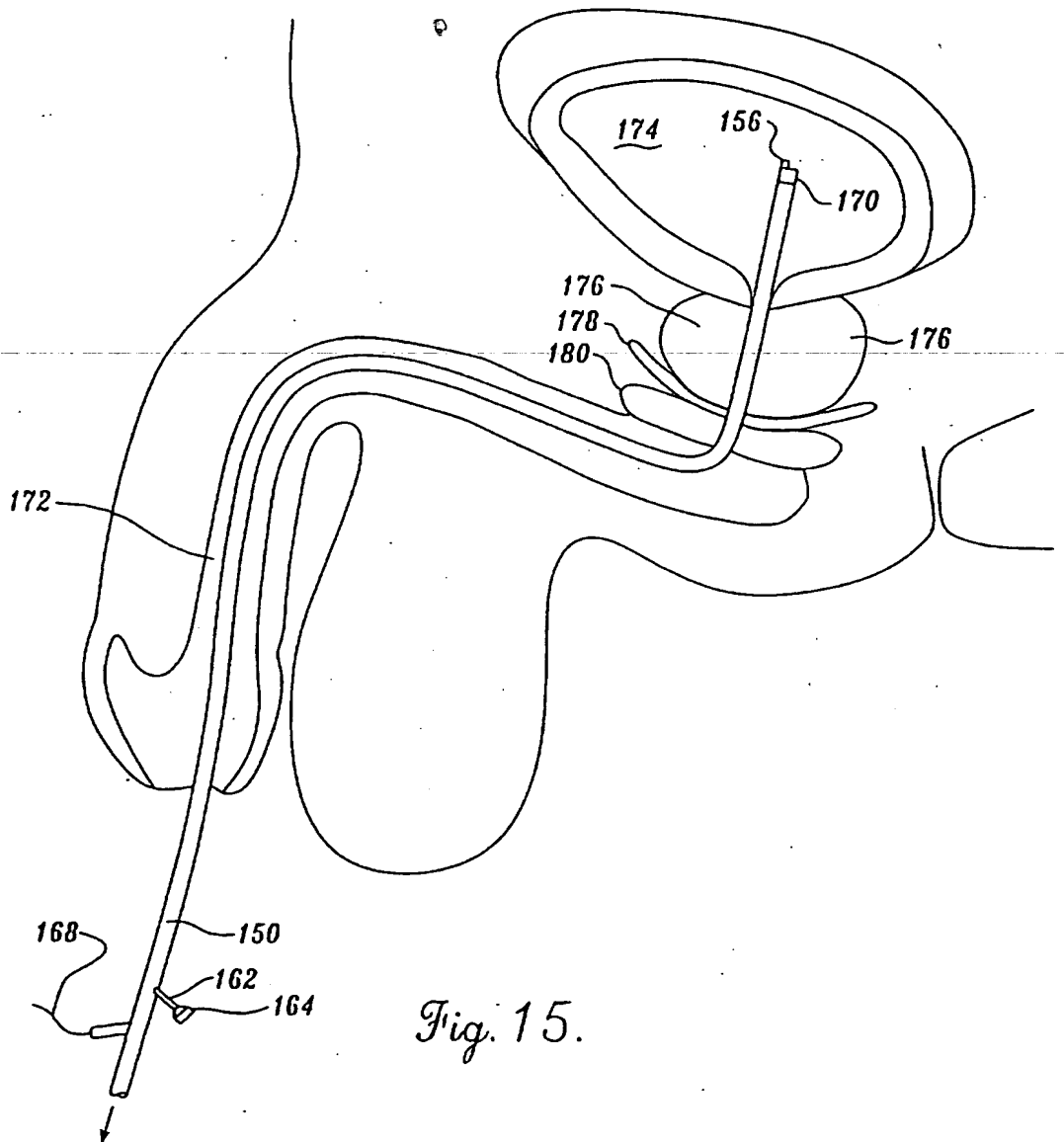

Fig. 15.

9/27

Fig. 16A.

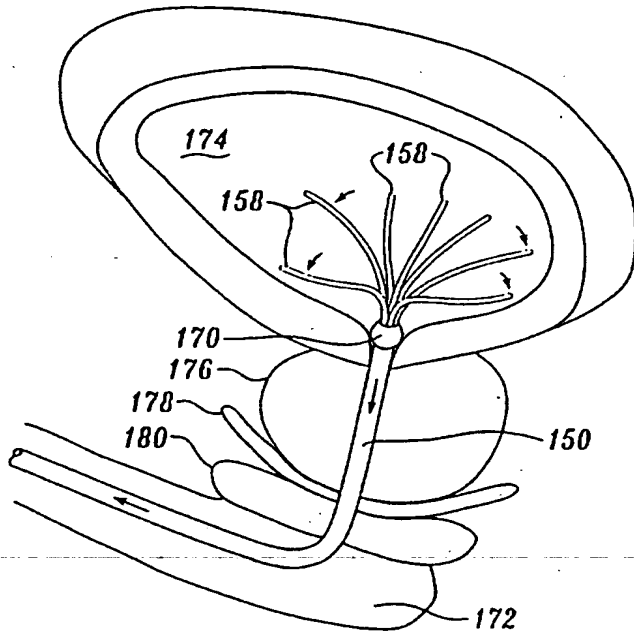

Fig. 16B.

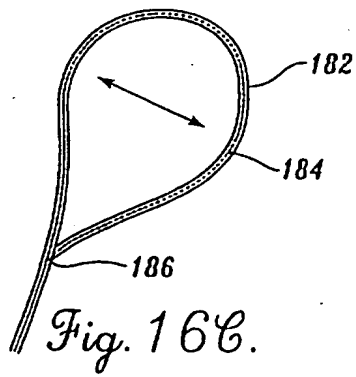
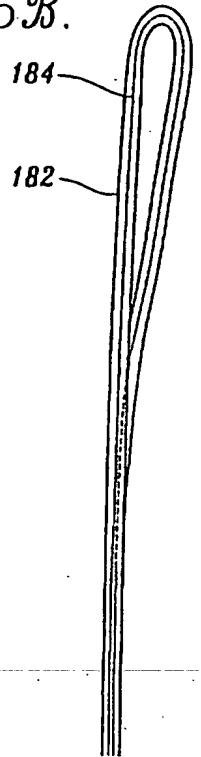
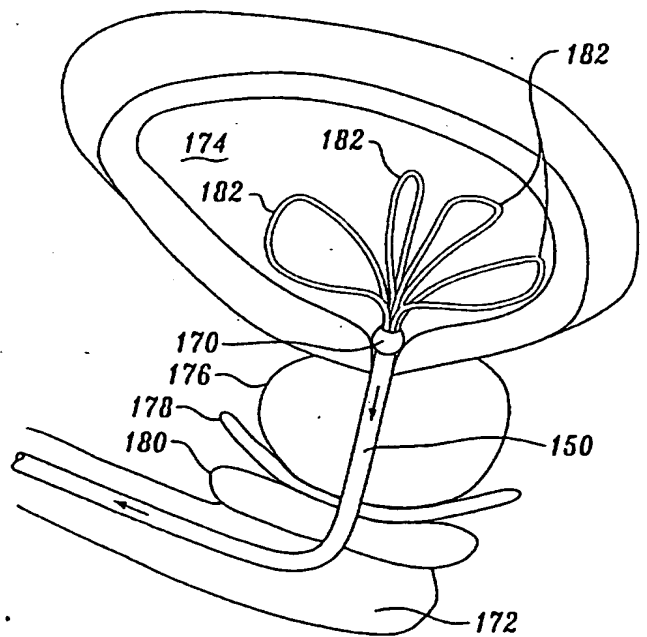

Fig. 16C.

Fig. 16D.



10/27

Fig. 17.

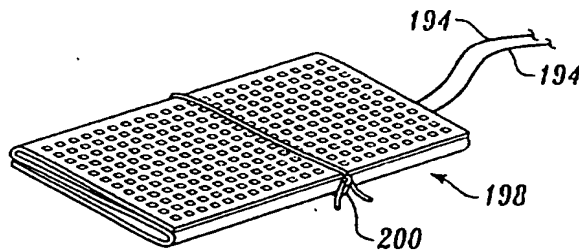
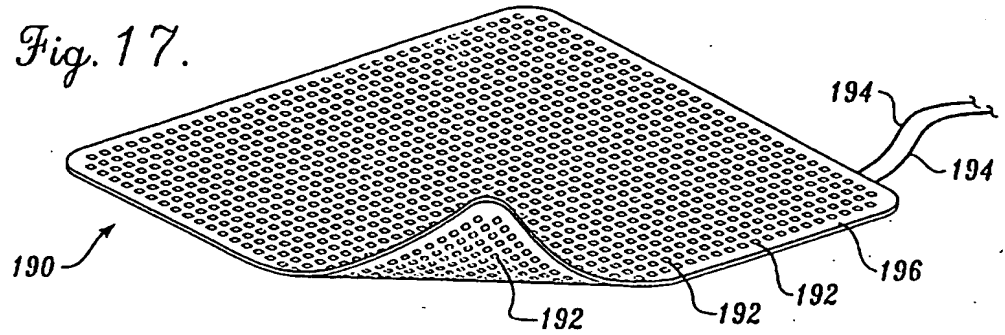

Fig. 18.

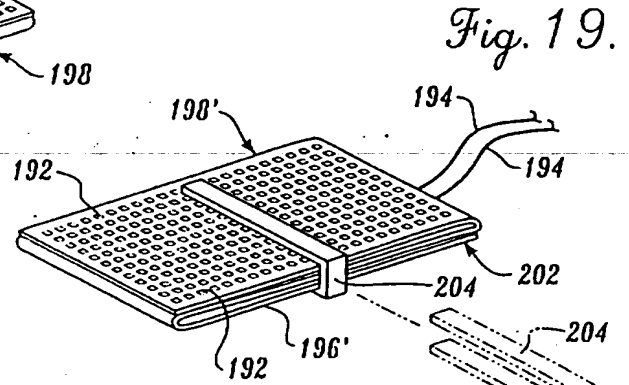

Fig. 19.

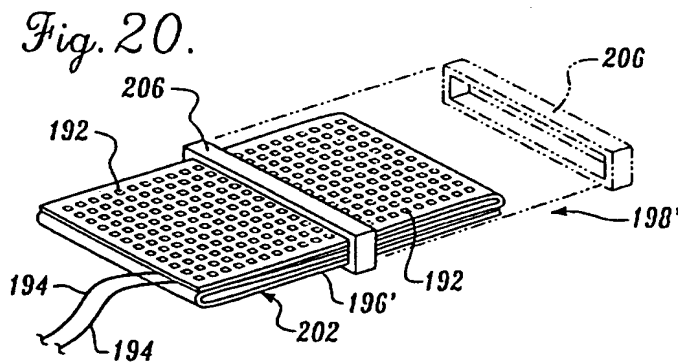

Fig. 20.

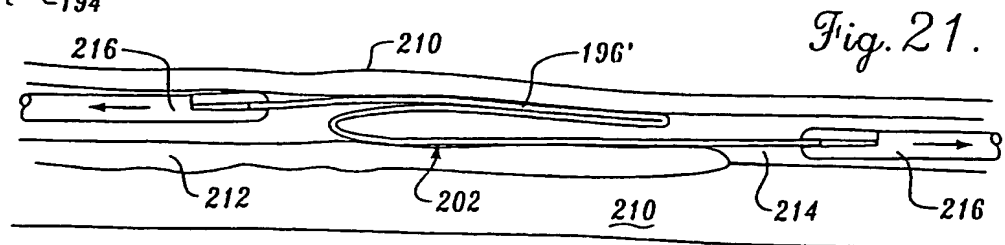

Fig. 21.

11/27

Fig. 22.

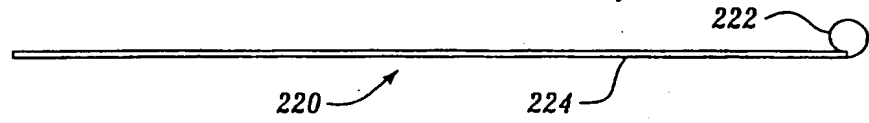

Fig. 23.



Fig. 24.



Fig. 25.

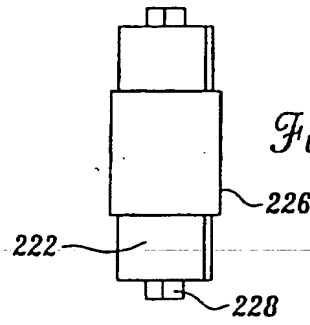
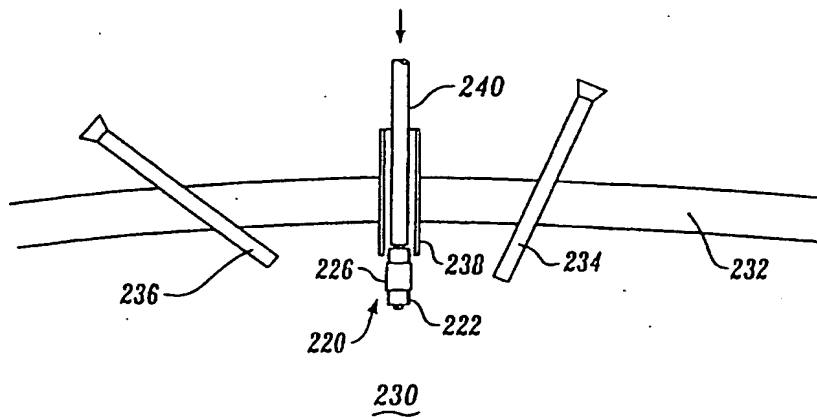
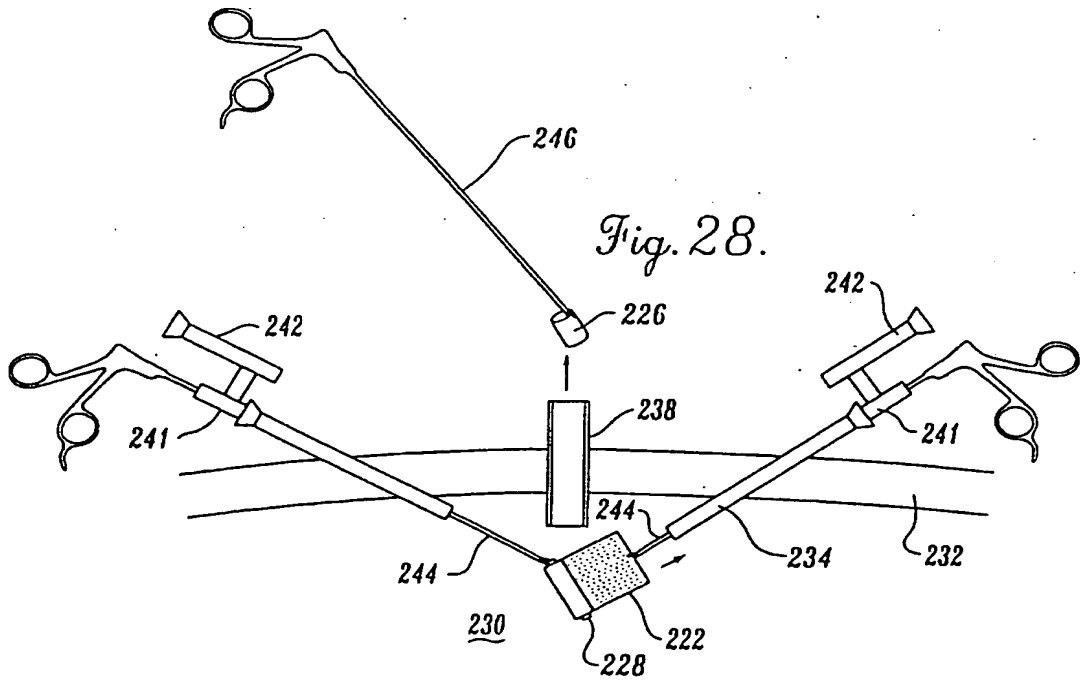
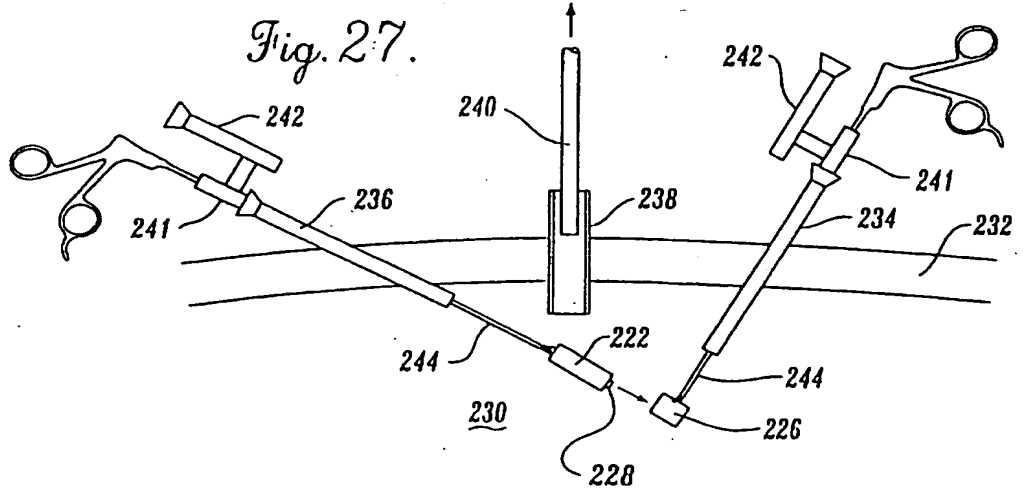

Fig. 26.



12/27



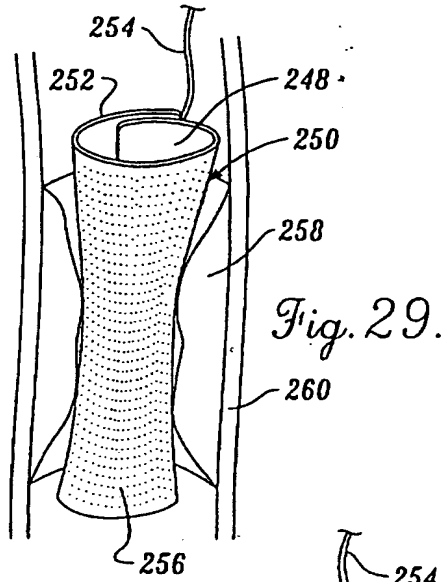

Fig. 29.

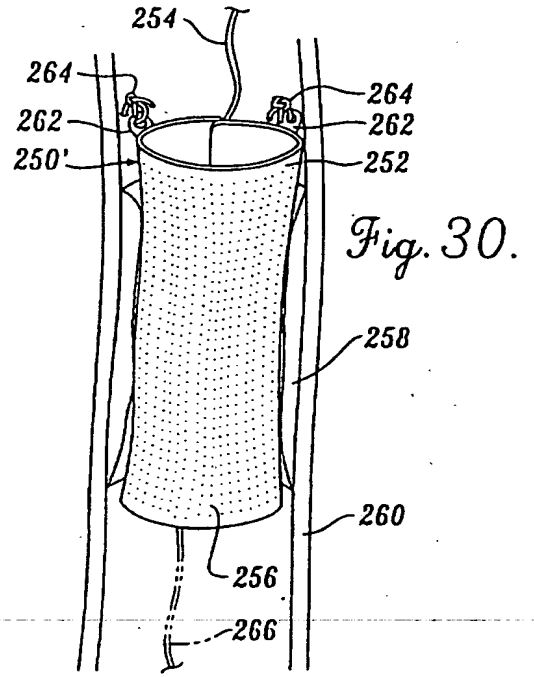

Fig. 30.

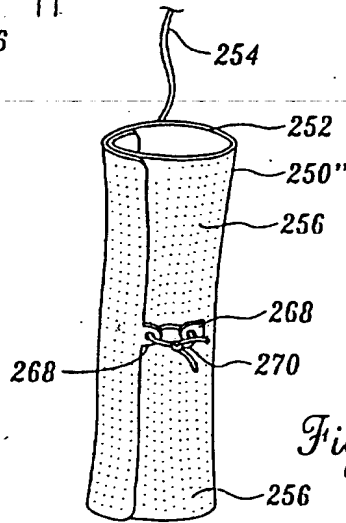

Fig. 30A.

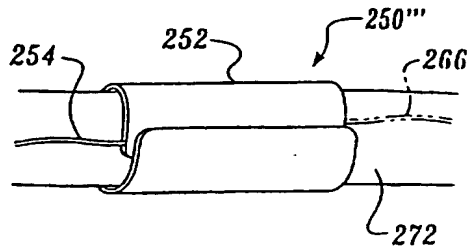

Fig. 31.

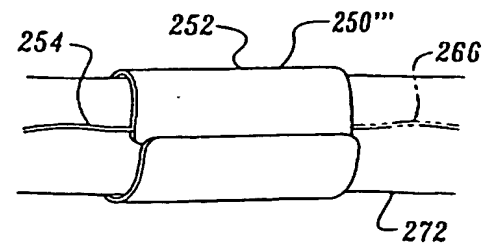
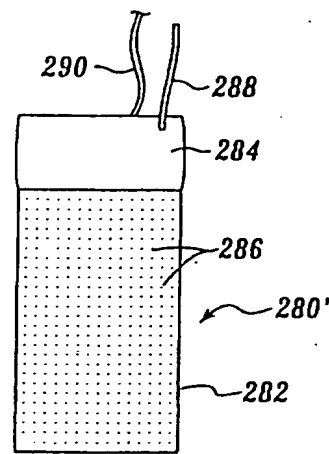
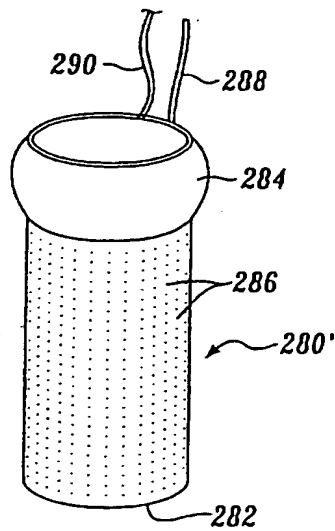
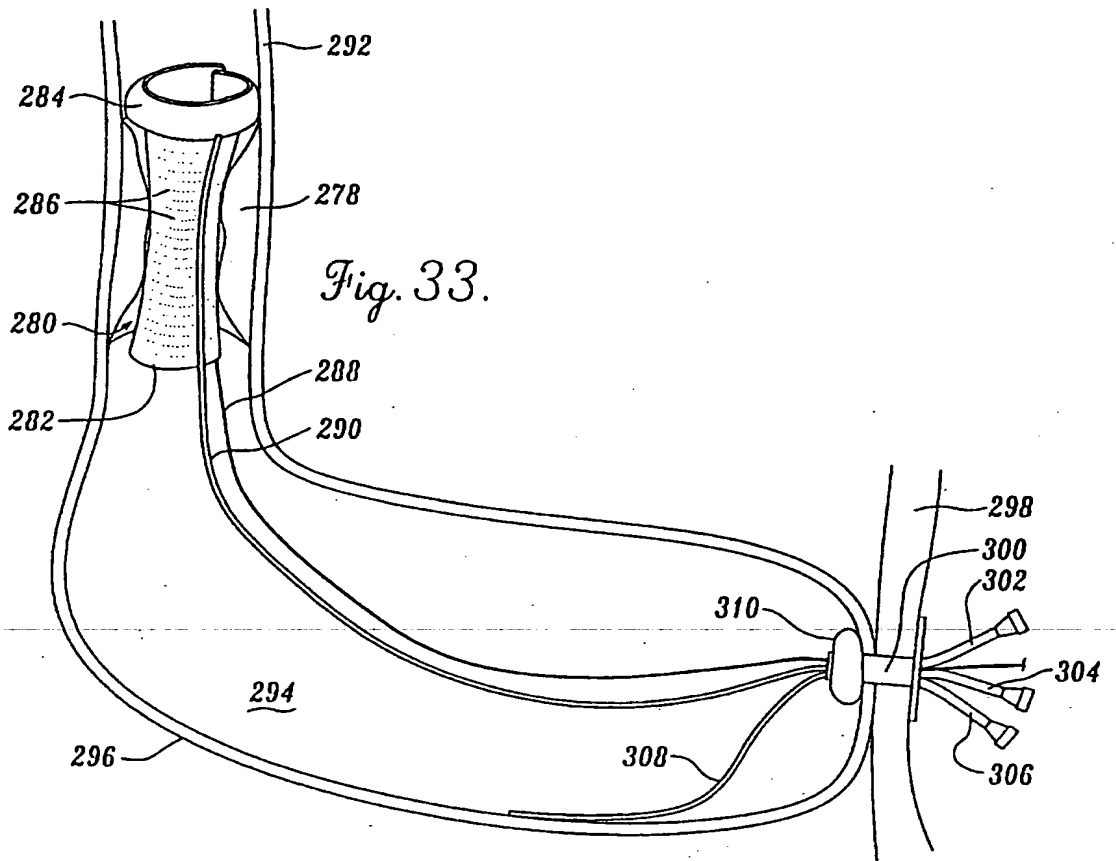

Fig. 32.



15/27

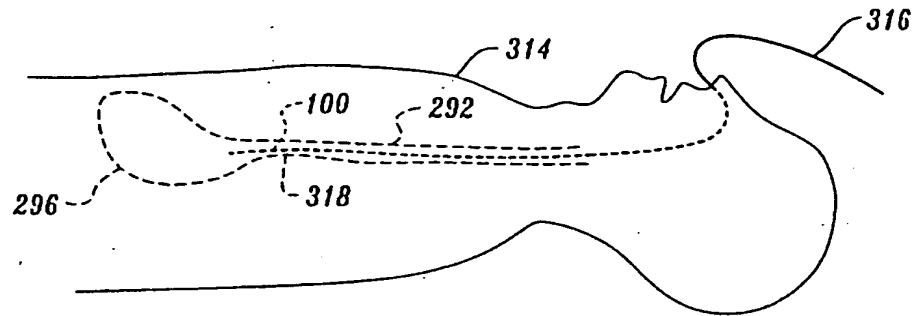

Fig. 36.

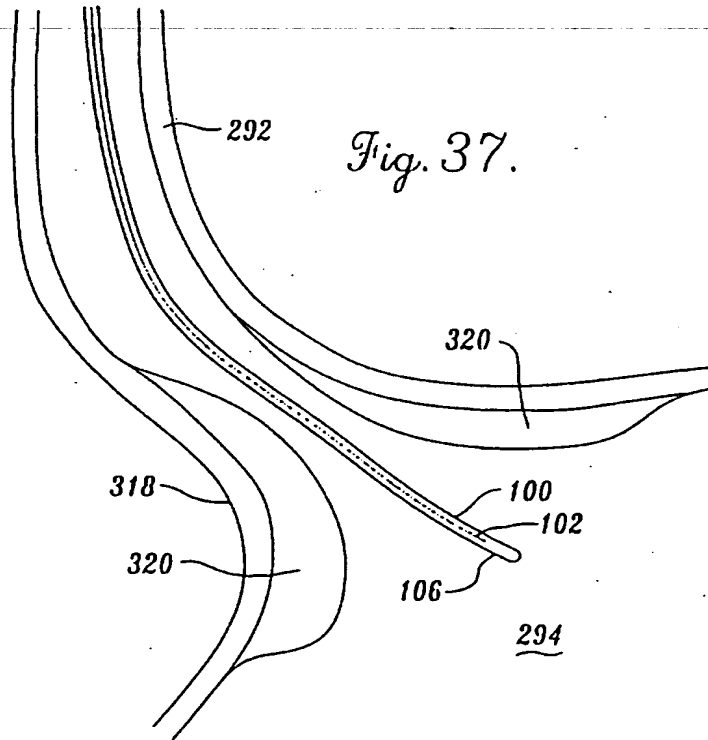

Fig. 37.

16/27

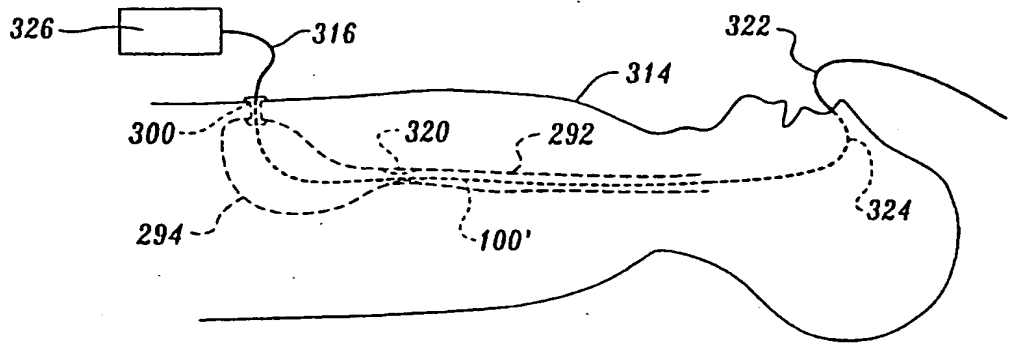

Fig. 38.

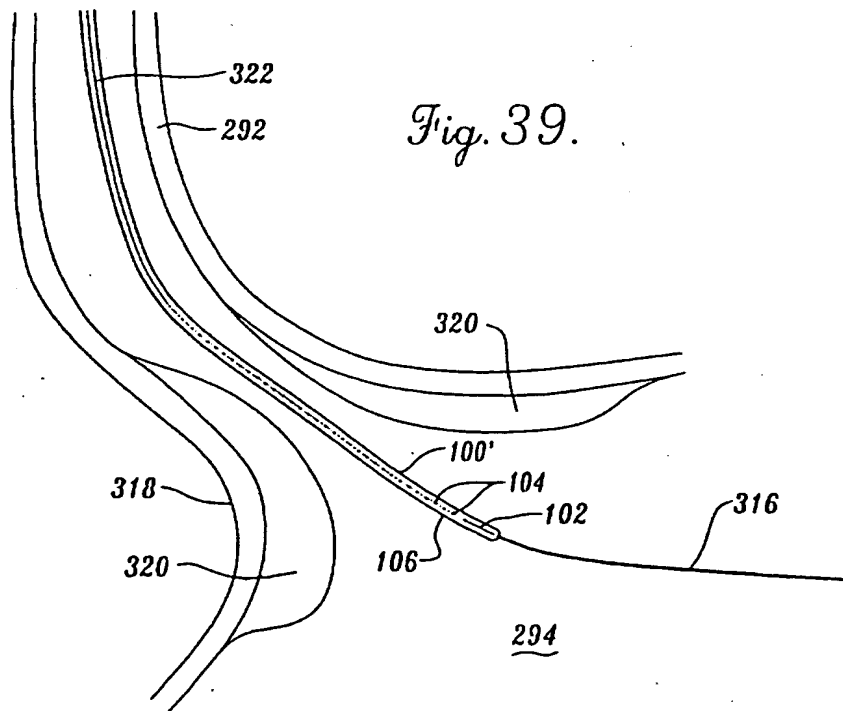

Fig. 39.

17/27

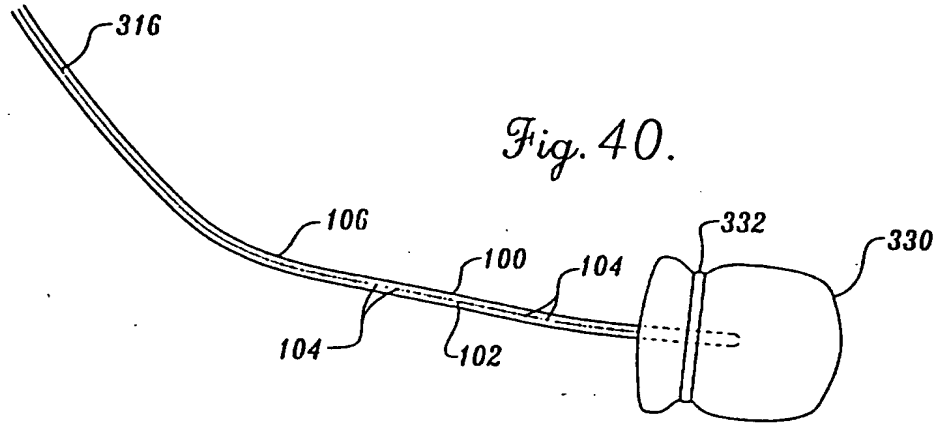

Fig. 40.

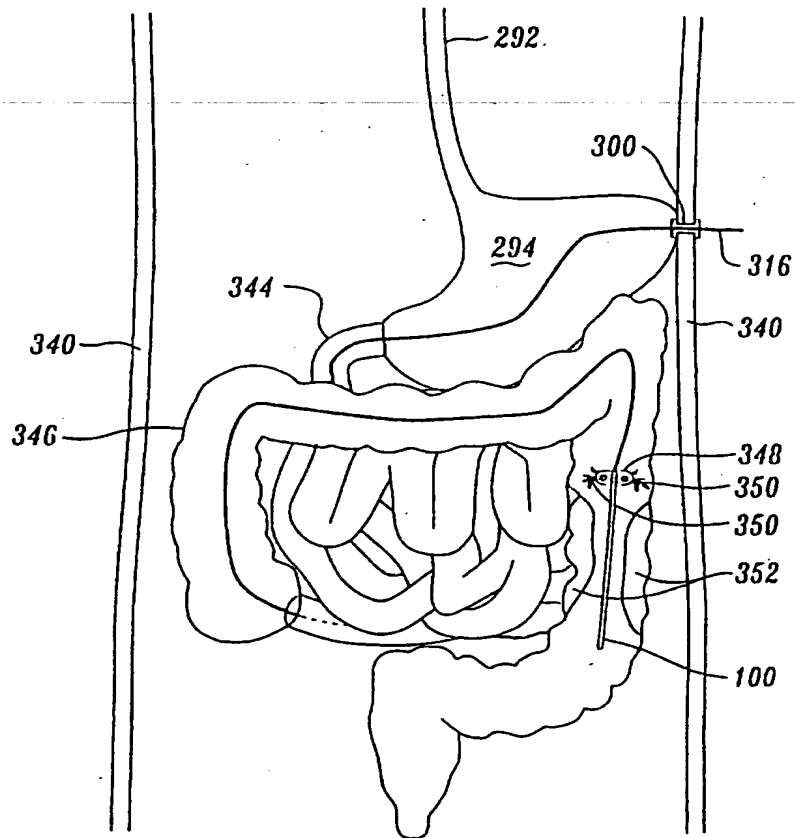

Fig. 41.

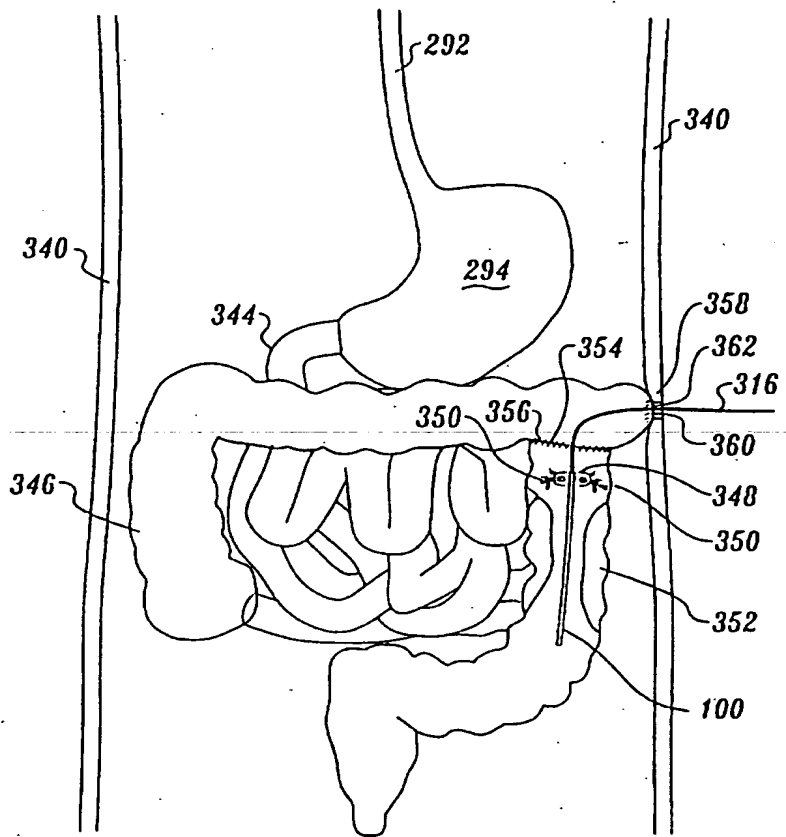
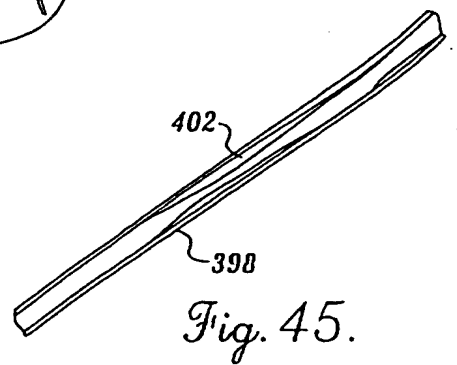
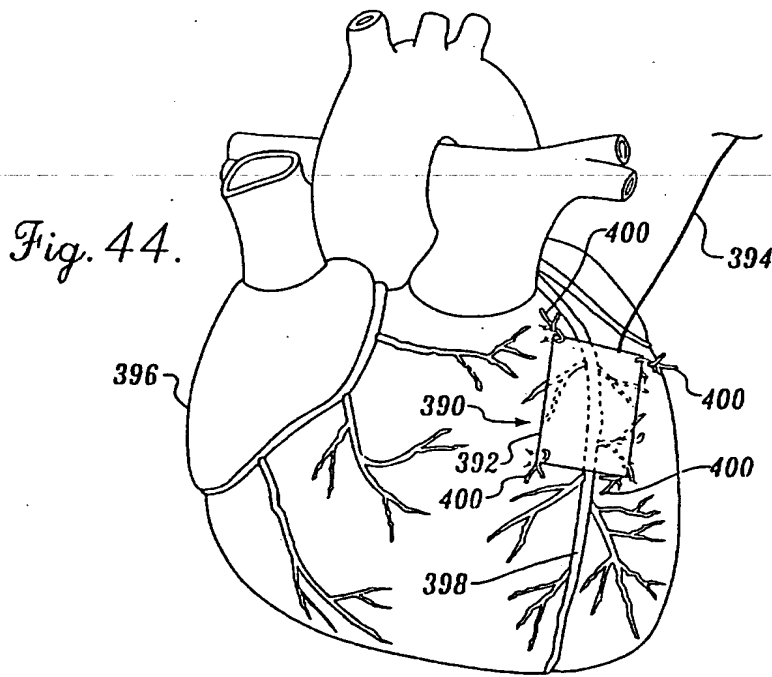
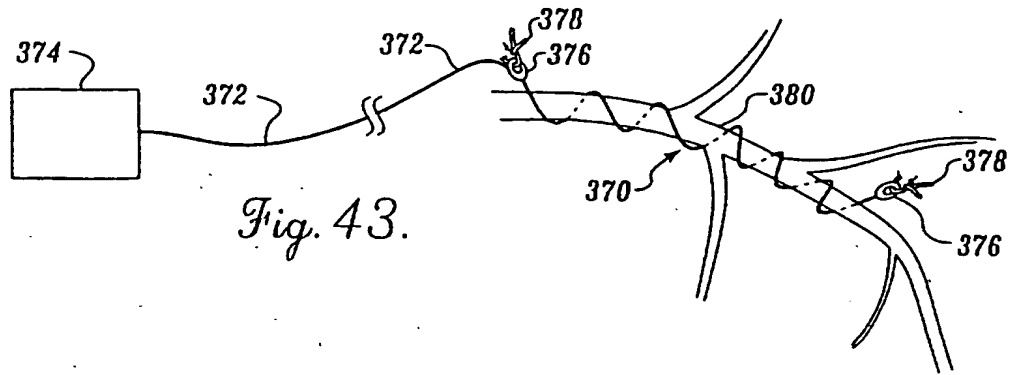

Fig. 42.



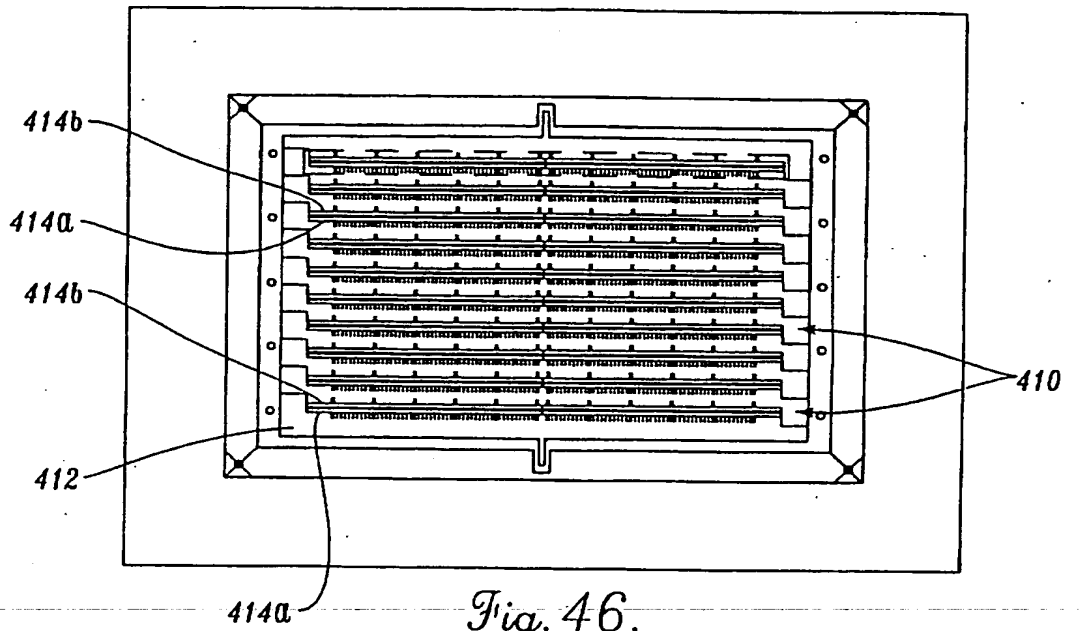

Fig. 46.

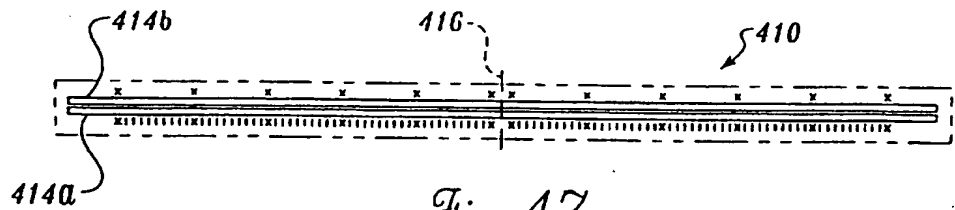

Fig. 47.

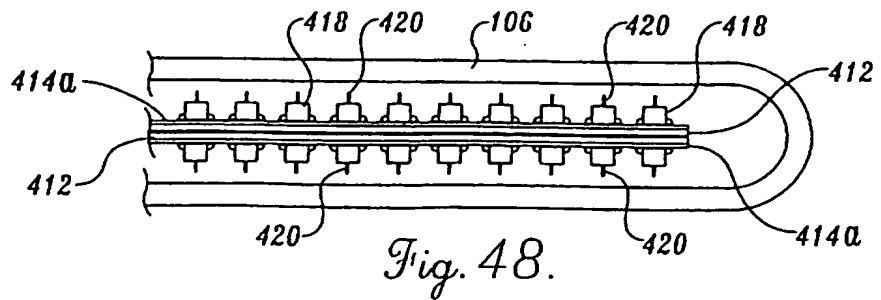

Fig. 48.

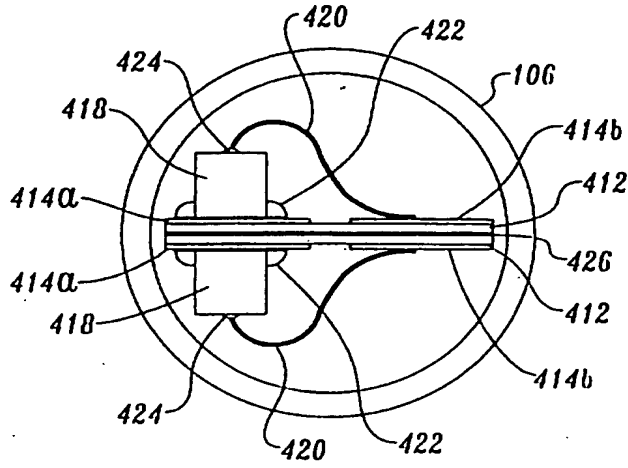

Fig. 49.

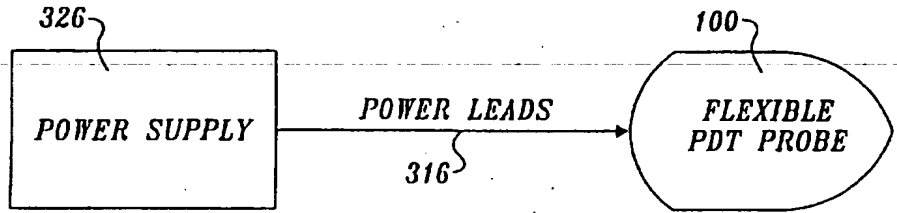

Fig. 50.

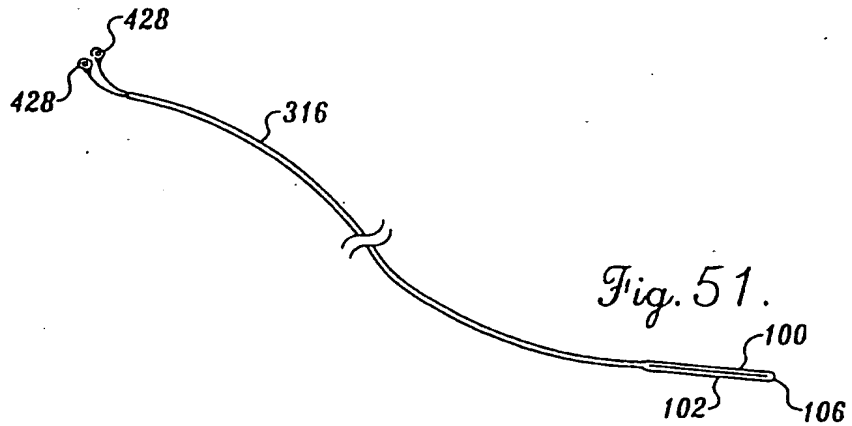

Fig. 51.

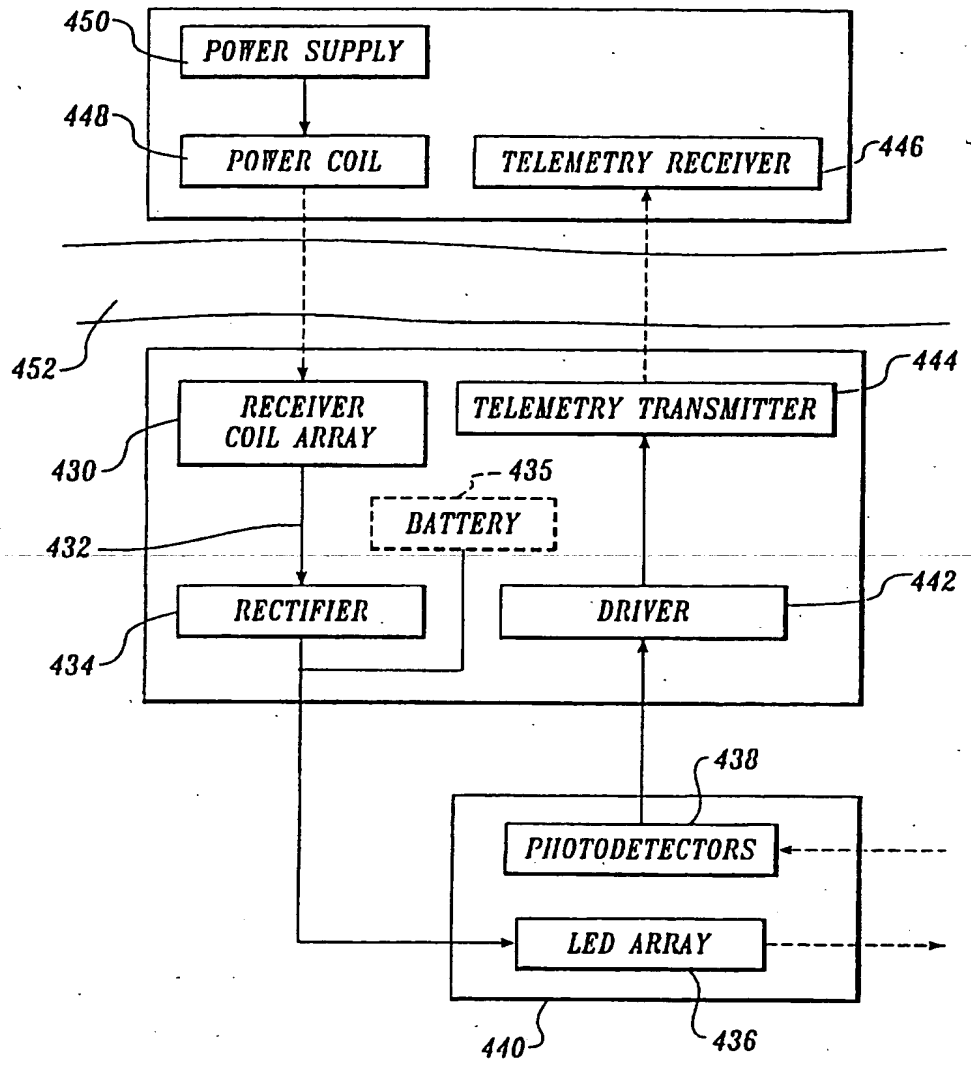

Fig. 52.

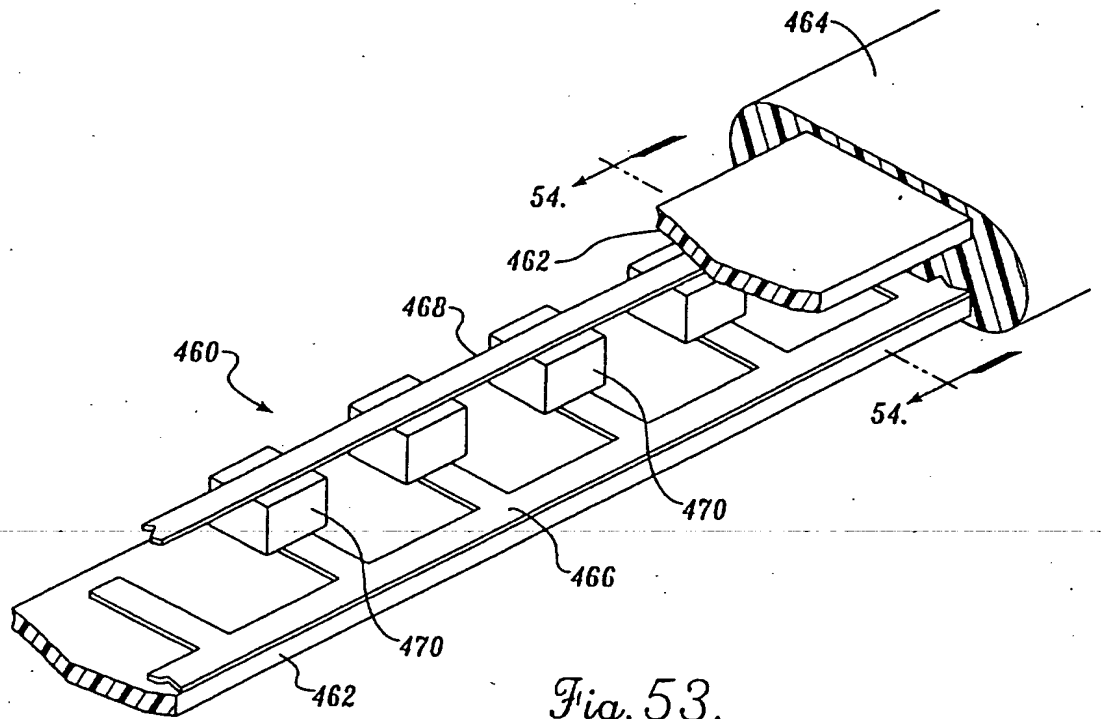

Fig. 53.

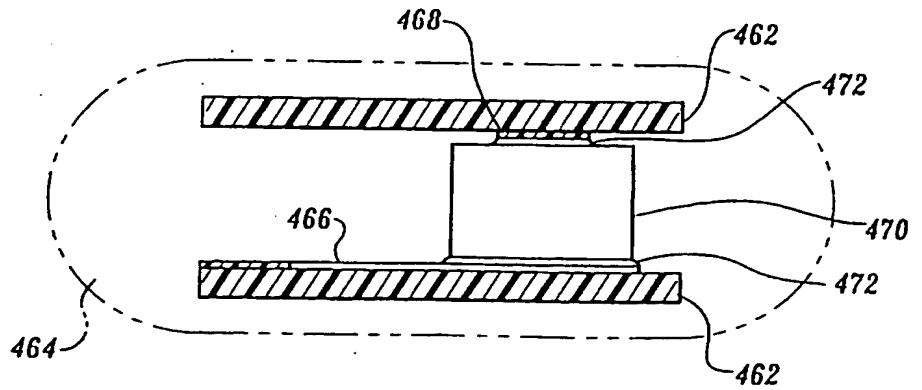

Fig. 54.

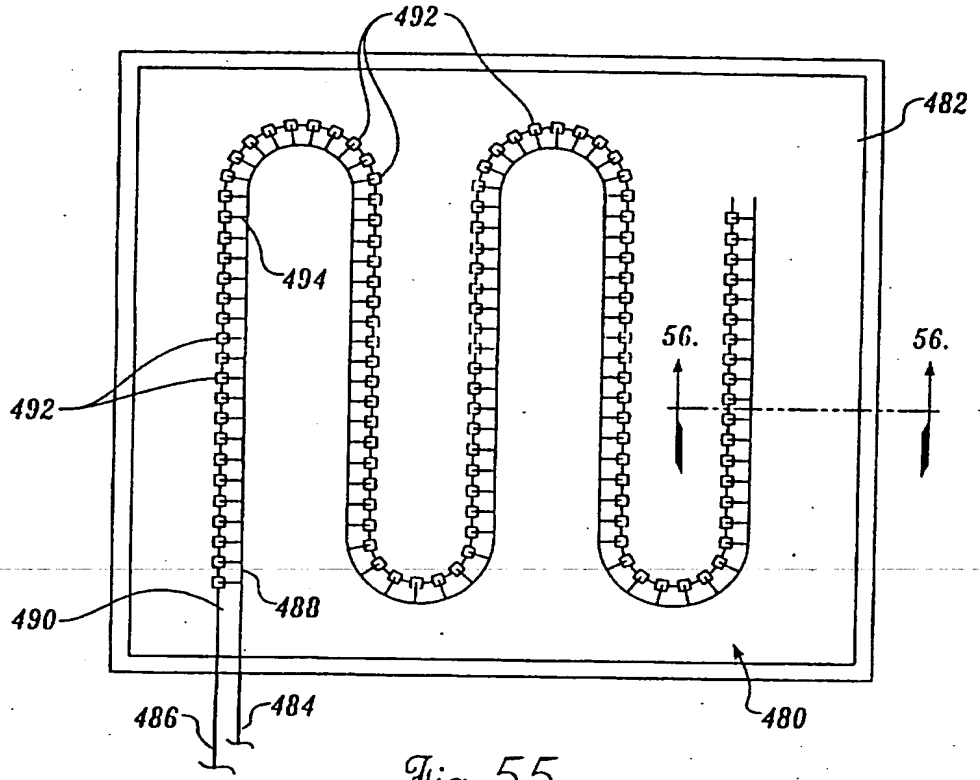

Fig. 55.

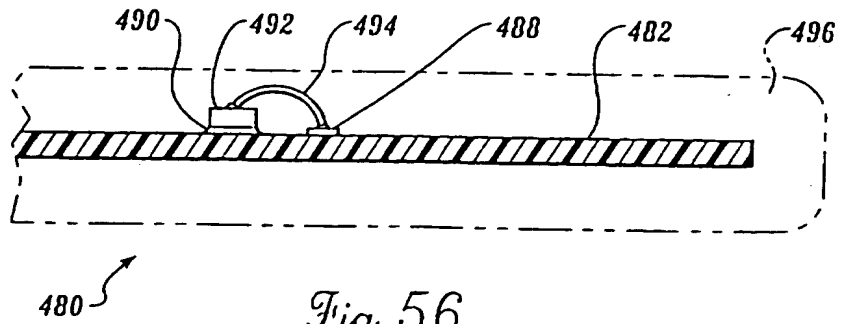

Fig. 56.

Fig. 57.

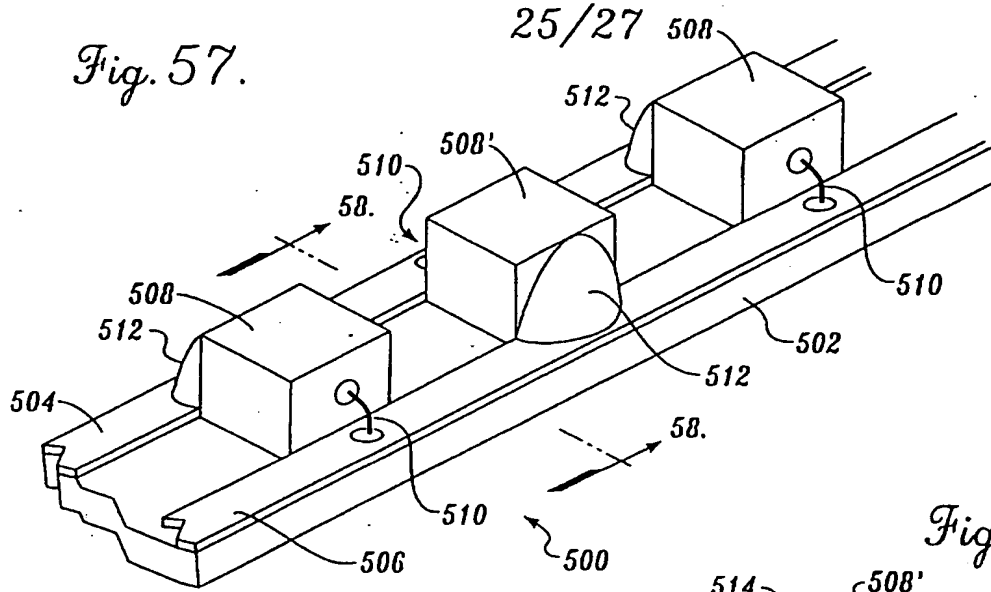
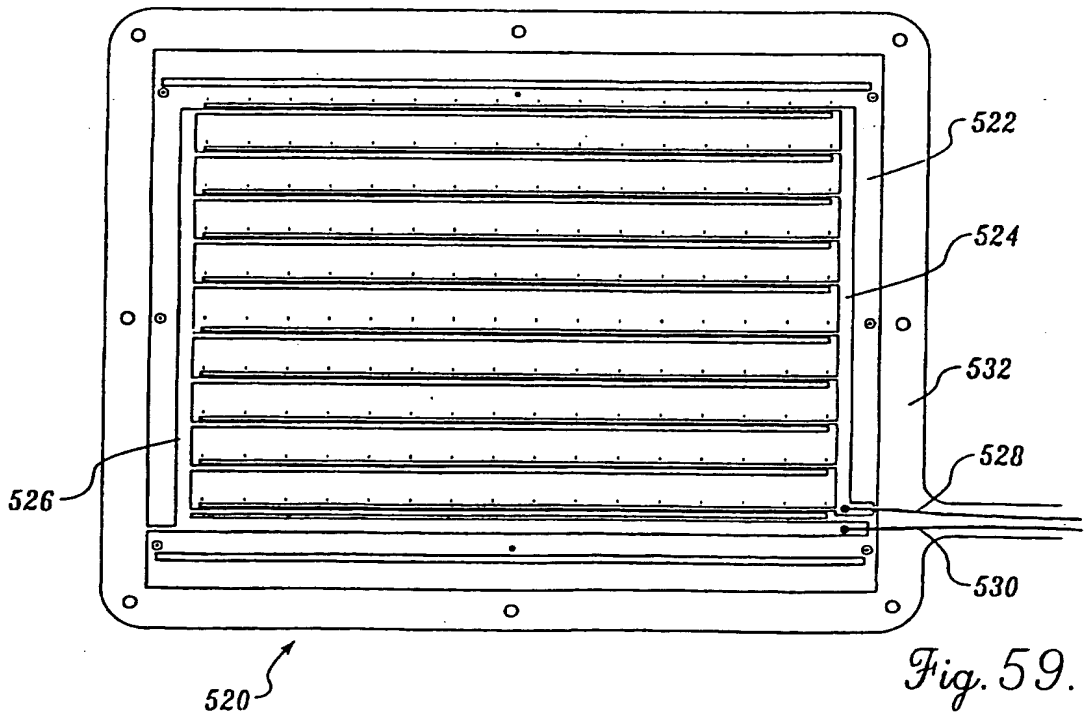
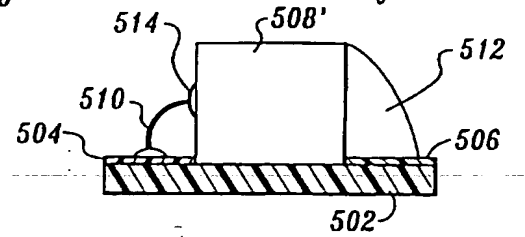

Fig. 58.



26/27

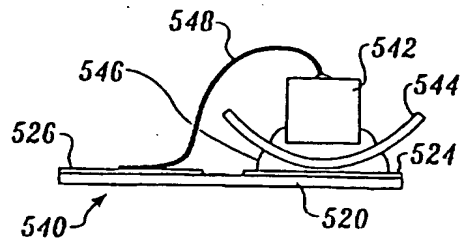

Fig. 60.

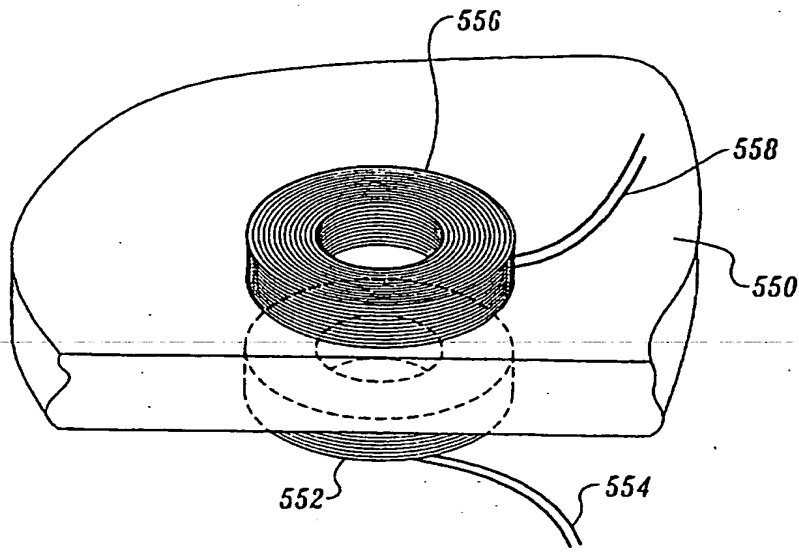

Fig. 61.

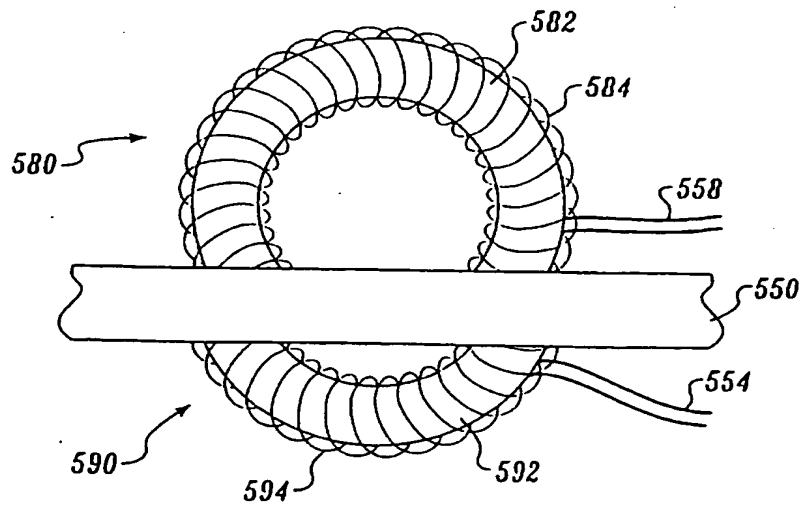

Fig. 62.

27/27

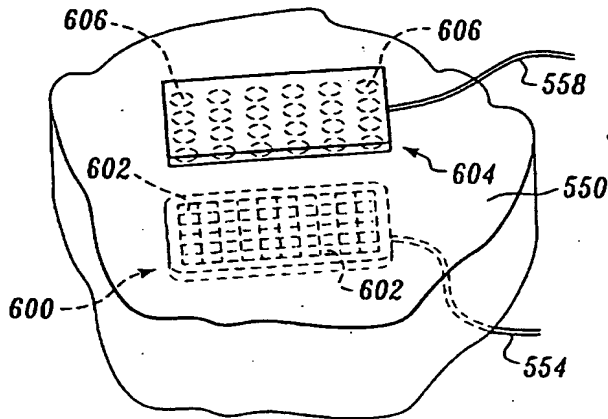

Fig. 63.

Fig. 64.

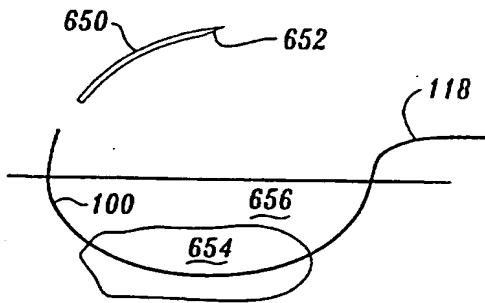
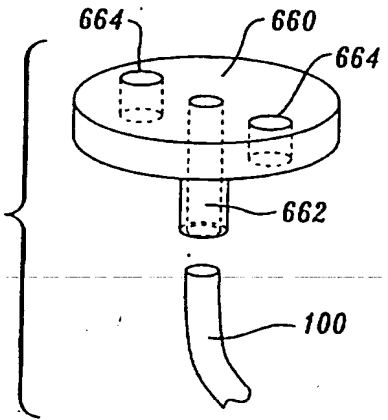

Fig. 65.

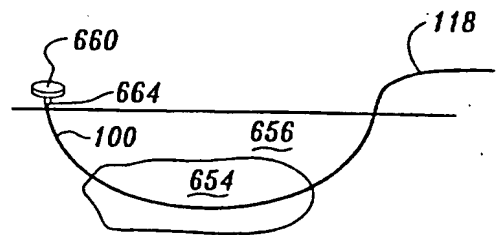

Fig. 66.

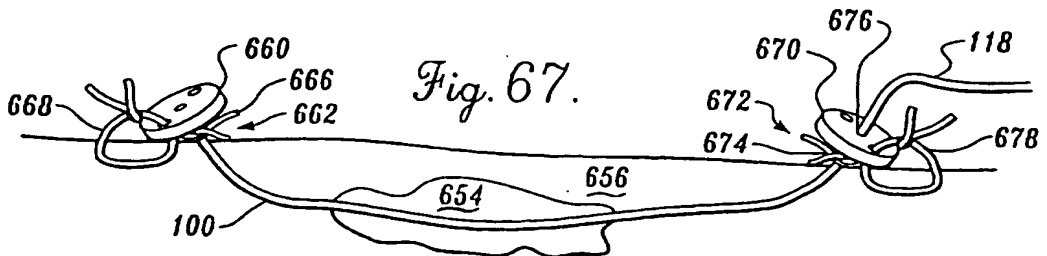
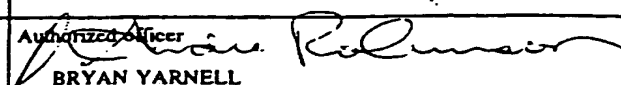

Fig. 67.

INTERNATIONAL SEARCH REPORT

International application No.
PCT/US97/02459

A. CLASSIFICATION OF SUBJECT MATTER				
IPC(6) :Please See Extra Sheet. US CL :128/642, 898; 606/2; 607/88, 116 According to International Patent Classification (IPC) or to both national classification and IPC				
B. FIELDS SEARCHED				
Minimum documentation searched (classification system followed by classification symbols) U.S. : 128/642, 898, 899; 604/19-21; 606/1, 2, 13, 14; 607/88, 89, 115, 116, 129, 132				
Documentation searched other than minimum documentation to the extent that such documents are included in the fields searched				
Electronic data base consulted during the international search (name of data base and, where practicable, search terms used)				
C. DOCUMENTS CONSIDERED TO BE RELEVANT				
Category*	Citation of document, with indication, where appropriate, of the relevant passages	Relevant to claim No.		
X --- Y	US 5,314,463 A (CAMPS et al) 24 May 1994, Fig. 18; and col. 7 line 48 to col. 8 line 25.	1-4, 8-24 ----- 7		
X	US 5,390,671 A (LORD et al) 21 February 1995, Fig. 1; and col. 3, lines 5-16.	16		
A	US 4,010,756 A (DUMONT et al) 08 March 1977, entire document.	1, 8, 16, 22		
<input type="checkbox"/> Further documents are listed in the continuation of Box C. <input type="checkbox"/> See patent family annex.				
<table border="0" style="width:100%;"> <tr> <td style="width:50%; vertical-align: top;"> * Special categories of cited documents: *A* document defining the general state of the art which is not considered to be of particular relevance *E* earlier document published on or after the international filing date *L* document which may throw doubts on priority claim(s) or which is cited to establish the publication date of another citation or other special reasons (as specified) *O* document referring to an oral disclosure, use, exhibition or other means *P* document published prior to the international filing date but later than the priority date claimed </td> <td style="width:50%; vertical-align: top;"> *T* later document published after the international filing date or priority date and not in conflict with the application but cited to understand the principle or theory underlying the invention *X* document of particular relevance; the claimed invention cannot be considered novel or cannot be considered to involve an inventive step when the document is taken alone *Y* document of particular relevance; the claimed invention cannot be considered to involve an inventive step when the document is combined with one or more other such documents, such combination being obvious to a person skilled in the art *Δ* document member of the same patent family </td> </tr> </table>			* Special categories of cited documents: *A* document defining the general state of the art which is not considered to be of particular relevance *E* earlier document published on or after the international filing date *L* document which may throw doubts on priority claim(s) or which is cited to establish the publication date of another citation or other special reasons (as specified) *O* document referring to an oral disclosure, use, exhibition or other means *P* document published prior to the international filing date but later than the priority date claimed	*T* later document published after the international filing date or priority date and not in conflict with the application but cited to understand the principle or theory underlying the invention *X* document of particular relevance; the claimed invention cannot be considered novel or cannot be considered to involve an inventive step when the document is taken alone *Y* document of particular relevance; the claimed invention cannot be considered to involve an inventive step when the document is combined with one or more other such documents, such combination being obvious to a person skilled in the art *Δ* document member of the same patent family
* Special categories of cited documents: *A* document defining the general state of the art which is not considered to be of particular relevance *E* earlier document published on or after the international filing date *L* document which may throw doubts on priority claim(s) or which is cited to establish the publication date of another citation or other special reasons (as specified) *O* document referring to an oral disclosure, use, exhibition or other means *P* document published prior to the international filing date but later than the priority date claimed	*T* later document published after the international filing date or priority date and not in conflict with the application but cited to understand the principle or theory underlying the invention *X* document of particular relevance; the claimed invention cannot be considered novel or cannot be considered to involve an inventive step when the document is taken alone *Y* document of particular relevance; the claimed invention cannot be considered to involve an inventive step when the document is combined with one or more other such documents, such combination being obvious to a person skilled in the art *Δ* document member of the same patent family			
Date of the actual completion of the international search 16 MAY 1997		Date of mailing of the international search report 09 JUN 1997		
Name and mailing address of the ISA/US Commissioner of Patents and Trademarks Box PCT Washington, D.C. 20231 Facsimile No. (703) 305-3230		Authorized Officer  BRYAN YARNELL Telephone No. (703) 308-3173		

INTERNATIONAL SEARCH REPORT

International application No.
PCT/US97/02459

**A. CLASSIFICATION OF SUBJECT MATTER:
IPC (6):**

A61B 5/04, 17/36, 19/00; A61N 1/00